



# WISCONSIN ICECUBE PARTICLE ASTROPHYSICS CENTER

## IceCube Upgrade

2020001-19

### Approval

|                        |               |            |
|------------------------|---------------|------------|
| Principal Investigator | Kael Hanson   | 02/26/2020 |
| Project Manager        | Farshid Feyzi | 02/20/2020 |

### Change Log

| Rev | Description : Author                                                                                                                                                                                                                                                                                                                                   | Date     |
|-----|--------------------------------------------------------------------------------------------------------------------------------------------------------------------------------------------------------------------------------------------------------------------------------------------------------------------------------------------------------|----------|
| -   | Original document : J. Haugen                                                                                                                                                                                                                                                                                                                          | 1/24/18  |
| 1   | Initial Pre-award PEP: K. Hanson, J. Haugen, C. Vakhnina, M. DuVernois, R. Paulos, T. DeYoung                                                                                                                                                                                                                                                          | 7/9/18   |
| 2   | Second draft PEP: K. Hanson, J. Haugen, C. Vakhnina, M. DuVernois, R. Paulos, T. DeYoung, J. Yeck. WBS to level 4, improved risk and contingency                                                                                                                                                                                                       | 8/22/18  |
| 3   | Third draft PEP: K. Hanson, J. Haugen, C. Vakhnina, M. DuVernois, R. Paulos, T. DeYoung, J. Yeck. Updated summary tables on p.17-18 and 42, and text on p.46                                                                                                                                                                                           | 8/27/18  |
| 4   | Revised PEP: J. Madsen. Removed WBS Dictionary and provided link to updated WBS Dictionary, Updated Organization Charts to be consistent with new WBS, Removed cost by WBS item and added description of Cost Book, Updated personnel, added EV reporting description, Updated the Design Flow Matrix and a Draft Risk Management Plan in the appendix | 2/12/19  |
| 5   | Revised PEP: J. Madsen. Added Section 1.5 Technical baseline (p.8-10), Updated Organization chart (Fig. 2, p. 11). Aligned 2.1.2 Project Office Senior Staff description                                                                                                                                                                               | 3/1/2019 |

222 West Washington Avenue  
Madison, WI 53703  
contact-us@icecube.wisc.edu

Telephone: +1.608.890.0548  
FAX: +1.608.262.2309

2020001-19

|    |                                                                                                                                                                                                                                                                                                                                                                                                                                                                                                                                                                                                                                                                                                                                                                                                                                                                                                                                                                                                                                                                                                                                                                                                                                                                                                                                                                                                                                                                                                                                                                                                                                                                                                                                          |            |
|----|------------------------------------------------------------------------------------------------------------------------------------------------------------------------------------------------------------------------------------------------------------------------------------------------------------------------------------------------------------------------------------------------------------------------------------------------------------------------------------------------------------------------------------------------------------------------------------------------------------------------------------------------------------------------------------------------------------------------------------------------------------------------------------------------------------------------------------------------------------------------------------------------------------------------------------------------------------------------------------------------------------------------------------------------------------------------------------------------------------------------------------------------------------------------------------------------------------------------------------------------------------------------------------------------------------------------------------------------------------------------------------------------------------------------------------------------------------------------------------------------------------------------------------------------------------------------------------------------------------------------------------------------------------------------------------------------------------------------------------------|------------|
|    | with Org. chart (p.12). Removed associate director from list of responsibilities of host institution (p. 14). Added L1 and L2 Milestones (p.18-21). Updated Summary of Total Project Definition, Non-NSF Funding Table to be updated (p.22). Updated US Funding profile by institution (p.29).                                                                                                                                                                                                                                                                                                                                                                                                                                                                                                                                                                                                                                                                                                                                                                                                                                                                                                                                                                                                                                                                                                                                                                                                                                                                                                                                                                                                                                           |            |
| 6  | Revised PEP: J. Madsen. Update 2.2.3 ICNO description and added information on MOUs and how they are used to describe in-kind contributions (p.14), Updated Development Schedule items (p.17-18), fixed links for NSF IceCube Upgrade Review, Updated Design Flow matrix Appendix 1                                                                                                                                                                                                                                                                                                                                                                                                                                                                                                                                                                                                                                                                                                                                                                                                                                                                                                                                                                                                                                                                                                                                                                                                                                                                                                                                                                                                                                                      | 3/5/2019   |
| 10 | Revisions to address comments and recommendations from March 2019 project review panel. J. Madsen: Added Section 1.1.3 IceCube-Gen2 R&D. Updated Fig.2 removing IDF and adding surface junction box, removed IDF from text in Section 1.2.3, Improved text in section 3 opening paragraph. Removed IDF references in Milestones and added SBJ. Moved Upgrade design flow matrix from appendix 1 to where it is referenced in 3.1.2 and eliminated the appendix. Removed section heading 4.5.1 Risk Register but kept text. Updated 2.1.2 Production Manager title corrected to Production Coordinator, 2.1.1 Updated to include Farshid Feyzi as PM, Updated reporting section 11. 3 to reflect monthly reports rather than quarterly as previously described. Updated link and text in 6 to refer to IceCube Upgrade Risk Management and Mitigation Plan (previous text said this was under development) and removed the redundant appendix.<br><br>M. DuVernois: 1.2.3 Removed reference to IDF and added surface junction box, added sentence in 2.1.2 clarifying Technical Coordinator duties and in 2.1.4 about face-to-face meetings of Tech Board at Collaboration Meetings, Updated roles and responsibilities table in 2.3 for UW–Madison and Penn State, Reformatted personnel organization in 5 Staffing Plan. Updated information on major acquisitions in 8.1. Updated internal reviews Section 11.1 clarifying Subsystem Technical Reviews Configuration Board Meeting descriptions. Added Section 13.1 Physics, Calibration, and R&D Success Key Performance Parameters. Added Section 13 Reliability.<br><br>F. Feyzi: Reorganized to follow guidelines of Major Facilities Guide. Edited for content and updated plans. | 8/30/2019  |
| 11 | Edited by J. DeMerit and F. Feyzi                                                                                                                                                                                                                                                                                                                                                                                                                                                                                                                                                                                                                                                                                                                                                                                                                                                                                                                                                                                                                                                                                                                                                                                                                                                                                                                                                                                                                                                                                                                                                                                                                                                                                                        | 9/25/2019  |
| 12 | M. DuVernois, general edit, addition of 1.1.3, modifications for “transition to operations,” improved figures 6 & removed the old figure 7, and clarifications in section 13. Edited by Feyzi                                                                                                                                                                                                                                                                                                                                                                                                                                                                                                                                                                                                                                                                                                                                                                                                                                                                                                                                                                                                                                                                                                                                                                                                                                                                                                                                                                                                                                                                                                                                            | 9/28/2019  |
| 13 | Edits by K. Hanson: scientific requirements, risk management plan removed and referenced to external document                                                                                                                                                                                                                                                                                                                                                                                                                                                                                                                                                                                                                                                                                                                                                                                                                                                                                                                                                                                                                                                                                                                                                                                                                                                                                                                                                                                                                                                                                                                                                                                                                            | 10/04/2019 |
| 14 | Updated section 4.2 per PY2 detail plan. Reissued with name change to 2019001-14 for comments by NSF, all revisions up to 13 are designated as archival. F. Feyzi                                                                                                                                                                                                                                                                                                                                                                                                                                                                                                                                                                                                                                                                                                                                                                                                                                                                                                                                                                                                                                                                                                                                                                                                                                                                                                                                                                                                                                                                                                                                                                        | 10/11/2019 |

2020001-19

|     |                                                                                                                                                                                                                                                                                                                                                                                       |            |
|-----|---------------------------------------------------------------------------------------------------------------------------------------------------------------------------------------------------------------------------------------------------------------------------------------------------------------------------------------------------------------------------------------|------------|
| 14a | Updated figure 1 and financial tables in section 4 based on comments from NSF. F. Feyzi                                                                                                                                                                                                                                                                                               | 11/1/2019  |
| 15  | Updated per additional comments from NSF. F. Feyzi                                                                                                                                                                                                                                                                                                                                    | 11/22/2019 |
| 16  | Updated per additional comments from NSF. F. Feyzi                                                                                                                                                                                                                                                                                                                                    | 12/4/2019  |
| 17  | Updated to address additional comments from NSF. F. Feyzi<br><br>Fixed revisions notes for rev 10 to ensure section numbers correspond to those after reorganization, which was done during rev 10. Section numbers and pages referenced in rev notes prior to rev10 are no longer current.<br><br>Recommendation re. calibration added to section 12.<br><br>Reissued as 20200010-17 | 1/12/2020  |
| 18  | Updated tables 6, 7 and 9 per changes in Cooperative Agreement<br><br>Inserted Appendix 4: Contributions in Kind<br><br>F. Feyzi                                                                                                                                                                                                                                                      | 1/20/2020  |
| 19  | Updated to address additional comments from NSF. F. Feyzi                                                                                                                                                                                                                                                                                                                             | 1/29/2020  |

2020001-19

|            |                                                                   |           |
|------------|-------------------------------------------------------------------|-----------|
| <b>1</b>   | <b>Introduction and Overview .....</b>                            | <b>9</b>  |
| <b>1.1</b> | <b>Scientific Objectives .....</b>                                | <b>9</b>  |
| 1.1.1      | Neutrino Properties .....                                         | 9         |
| 1.1.2      | Recalibration and Reanalysis of IceCube Data .....                | 9         |
| 1.1.3      | IceCube-Gen2 Research and Development.....                        | 10        |
| <b>1.2</b> | <b>Scientific Requirements .....</b>                              | <b>10</b> |
| 1.2.1      | Management Context of Physical Facilities .....                   | 11        |
| 1.2.2      | Infrastructure Overview .....                                     | 11        |
| 1.2.3      | Technical Facilities Overview.....                                | 11        |
| 1.2.4      | Technical Facilities Design .....                                 | 12        |
| 1.2.5      | Baseline Documentation .....                                      | 14        |
| <b>2</b>   | <b>Organization .....</b>                                         | <b>14</b> |
| <b>2.1</b> | <b>Internal Governance, Organization, and Communication .....</b> | <b>15</b> |
| 2.1.1      | Project Manager .....                                             | 15        |
| 2.1.2      | Project Office Senior Staff .....                                 | 15        |
| 2.1.3      | Level 2 and Level 3 Managers .....                                | 16        |
| 2.1.4      | Technical Board .....                                             | 16        |
| 2.1.5      | Change Control Board.....                                         | 16        |
| <b>2.2</b> | <b>External Organization and Partnerships .....</b>               | <b>17</b> |
| 2.2.1      | National Science Foundation .....                                 | 17        |
| 2.2.2      | International Oversight and Finance Group .....                   | 17        |
| 2.2.3      | IceCube Neutrino Observatory.....                                 | 17        |
| 2.2.4      | Host Institution.....                                             | 18        |
| <b>2.3</b> | <b>Partnerships, Roles, and Responsibilities.....</b>             | <b>18</b> |
| <b>2.4</b> | <b>Education and Outreach.....</b>                                | <b>20</b> |
| <b>3</b>   | <b>Design and Development .....</b>                               | <b>20</b> |
| <b>3.1</b> | <b>Project Design Planning.....</b>                               | <b>20</b> |
| 3.1.1      | Design Verification .....                                         | 21        |
| 3.1.2      | Project Management Structures for the Design Phase .....          | 21        |
| <b>3.2</b> | <b>Development Budget and Funding Sources .....</b>               | <b>22</b> |
| <b>3.3</b> | <b>Development Schedule and Milestones.....</b>                   | <b>23</b> |

2020001-19

|          |                                                           |           |
|----------|-----------------------------------------------------------|-----------|
| <b>4</b> | <b>Project Definition</b>                                 | <b>26</b> |
| 4.1      | Summary of Project Definition                             | 26        |
| 4.2      | Work Breakdown Structure (WBS)                            | 26        |
| 4.3      | Scope Management Plan and Scope Contingency               | 27        |
| 4.4      | Cost Estimating Plan, Cost Reports, and Baseline Budget   | 28        |
| 4.5      | Budget Contingency                                        | 28        |
| 4.5.1    | Risk Register                                             | 28        |
| 4.5.2    | Cost Uncertainty                                          | 28        |
| 4.6      | Funding Profile                                           | 30        |
| 4.7      | Project Year Detail Planning Process                      | 30        |
| 4.7.1    | Project Year Two Detail Planning                          | 30        |
| 4.8      | Baseline Schedule Estimating Plan and Integrated Schedule | 32        |
| <b>5</b> | <b>Staffing Plan</b>                                      | <b>32</b> |
| 5.1      | Project Manager                                           | 32        |
| 5.2      | Project Controls Manager                                  | 33        |
| 5.3      | Technical Coordinator                                     | 33        |
| 5.4      | Project Engineer                                          | 33        |
| 5.5      | Production Coordinator                                    | 33        |
| 5.6      | Safety and Quality Manager                                | 33        |
| 5.7      | Project Controls Specialist                               | 33        |
| <b>6</b> | <b>Risk Analysis and Mitigation</b>                       | <b>34</b> |
| <b>7</b> | <b>System Engineering and Configuration Control</b>       | <b>34</b> |
| 7.1      | System Engineering Plan                                   | 34        |
| 7.2      | Configuration Control Plan                                | 34        |
| 7.3      | Quality Systems and Safety                                | 34        |
| 7.4      | Design Baseline Documentation                             | 35        |
| <b>8</b> | <b>Acquisitions and Procurement</b>                       | <b>36</b> |
| 8.1      | Major Acquisitions                                        | 36        |
| 8.2      | Subcontract Management                                    | 37        |
| <b>9</b> | <b>Project Control Plan</b>                               | <b>37</b> |
| 9.1      | Earned Value Management System                            | 37        |

2020001-19

|                                                                                         |                                                                                   |           |
|-----------------------------------------------------------------------------------------|-----------------------------------------------------------------------------------|-----------|
| <b>9.2</b>                                                                              | <b>Financial and Business Controls .....</b>                                      | <b>38</b> |
| <b>10</b>                                                                               | <b>Site and Environment .....</b>                                                 | <b>39</b> |
| <b>10.1</b>                                                                             | <b>Site Selection.....</b>                                                        | <b>39</b> |
| <b>10.2</b>                                                                             | <b>Environmental Aspects.....</b>                                                 | <b>39</b> |
| <b>10.3</b>                                                                             | <b>Logistics .....</b>                                                            | <b>39</b> |
| <b>11</b>                                                                               | <b>Reviews and Reporting .....</b>                                                | <b>39</b> |
| <b>11.1</b>                                                                             | <b>Internal Reviews .....</b>                                                     | <b>39</b> |
| 11.1.1                                                                                  | Subsystem Technical Reviews .....                                                 | 40        |
| 11.1.2                                                                                  | Configuration Control Board Meetings.....                                         | 40        |
| 11.1.3                                                                                  | Project Advisory Panel Meetings .....                                             | 40        |
| 11.1.4                                                                                  | Science Advisory Committee and Software & Computing Advisory Panel Meetings ..... | 40        |
| <b>11.2</b>                                                                             | <b>External Reviews.....</b>                                                      | <b>40</b> |
| 11.2.1                                                                                  | IceCube International Oversight and Finance Group Meetings .....                  | 40        |
| 11.2.2                                                                                  | NSF Annual Reviews and Site Visits.....                                           | 40        |
| <b>11.3</b>                                                                             | <b>Reporting.....</b>                                                             | <b>41</b> |
| 11.3.1                                                                                  | Monthly Performance Reports .....                                                 | 41        |
| 11.3.2                                                                                  | Annual Reports.....                                                               | 41        |
| 11.3.3                                                                                  | Earned Value Management System (EVMS) Report.....                                 | 41        |
| <b>12</b>                                                                               | <b>Transition to Operations .....</b>                                             | <b>41</b> |
| <b>13</b>                                                                               | <b>Reliability and Overall Performance of the IceCube Upgrade.....</b>            | <b>42</b> |
| <b>13.1</b>                                                                             | <b>Physics, Calibration, and R&amp;D Success Key Performance Parameters .....</b> | <b>42</b> |
| <b>13.2</b>                                                                             | <b>Physics of Failure Methodology.....</b>                                        | <b>42</b> |
| 13.2.1                                                                                  | Role of Statistical Analysis .....                                                | 43        |
| 13.2.2                                                                                  | Failure Modes, Effects, and Criticality Analysis (FMECA) .....                    | 43        |
| 13.2.3                                                                                  | System Modeling .....                                                             | 43        |
| 13.2.4                                                                                  | Failure Review and Corrective Action.....                                         | 43        |
| <b>13.3</b>                                                                             | <b>Parts, Materials, and Process Selection .....</b>                              | <b>43</b> |
| 13.3.1                                                                                  | Determination of Prohibited Materials.....                                        | 44        |
| 13.3.2                                                                                  | Use of Commercial and Industrial Parts.....                                       | 44        |
| <b>Appendix 1: Flow Down from Scientific Objectives to Technical Requirements .....</b> |                                                                                   | <b>44</b> |
| <b>Appendix 2: Project Review Plan.....</b>                                             |                                                                                   | <b>46</b> |

2020001-19

**Appendix 3: List of Referenced Documents ..... 47**  
**Appendix 4: Contributions in Kind ..... 48**

THIS PAGE INTENTIONALLY LEFT BLANK



2020001-19

## 1 Introduction and Overview

The IceCube Phase I Upgrade, hereafter the IceCube Upgrade, seeks to enhance the scientific capabilities of the existing IceCube Neutrino Observatory at the South Pole station with a modest deployment of seven additional “strings” of advanced optical sensor instrumentation evolved from the highly successful IceCube digital optical module (DOM) design. IceCube encompasses  $10^9$  tons of optically transparent glacial ice that serves simultaneously as a massive target for neutrinos of atmospheric and astrophysical origin and a Cherenkov radiator medium producing the light detected by the array of optical sensors. IceCube, with an inter-string spacing of 125 meters and a spacing of 17 meters between sensors along the string, was originally optimized for detection of neutrinos in the energy range of 1 TeV to 1 PeV. During construction of IceCube, which we refer to as “Gen1,” a

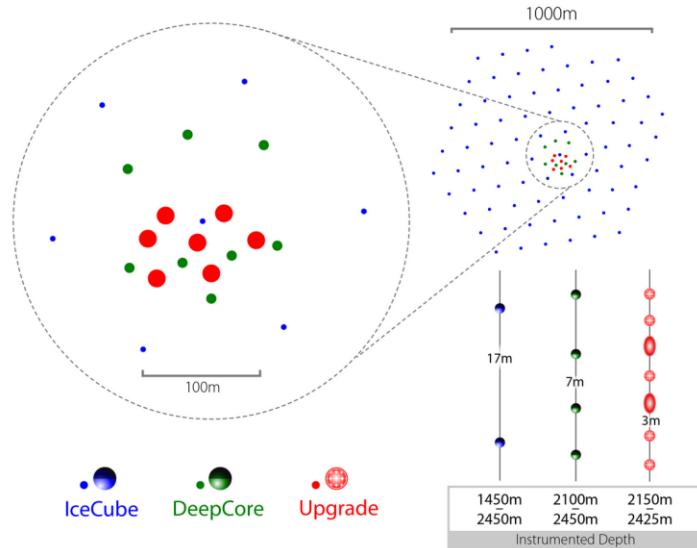

Figure 1: Deployment geometries of IceCube, DeepCore, and the IceCube Upgrade.

DeepCore infill array was deployed inside the IceCube strings to reduce the energy threshold to several tens of GeV. The IceCube Upgrade continues the trend by lowering the energy threshold to 5 GeV with the scientific objectives explained in the next section. The array geometries of IceCube, DeepCore, and the IceCube Upgrade are shown for comparison in Figure 1.

### 1.1 Scientific Objectives

#### 1.1.1 Neutrino Properties

The indirect observation of neutrino mass by reactor, accelerator, and astrophysical oscillation experiments requires additional physics beyond the Standard Model. IceCube DeepCore has demonstrated its capabilities in the domain of neutrino oscillation physics, and the IceCube Upgrade will increase scientific knowledge in the still mysterious neutrino sector. Precision measurement of the atmospheric neutrino mixing parameters may provide clues to new symmetries and new phenomena. The tau neutrino mixing parameters are poorly constrained in current oscillation experiments. However, the  $\nu_\tau$  appearance signal from atmospheric muon neutrinos oscillating in transit through Earth is in the middle of the IceCube Upgrade’s sensitivity region. More precise measurements of this column of the neutrino mixing matrix, the so-called PMNS matrix, could test the unitarity of this matrix, with failure of the unitarity condition indicating the presence of additional, sterile neutrinos.

#### 1.1.2 Recalibration and Reanalysis of IceCube Data

The imperfect knowledge of the optical properties of the ice, which forms an integral part of the IceCube detector, limits the angular resolution of event reconstructions. At high energies where the additional information content of the signal should continue to improve angular and energy resolutions,

2020001-19

reconstructions reach a resolution floor. The IceCube Upgrade presents an opportunity to deploy additional devices to measure ice properties that benefit from a decade of experience operating IceCube. The resulting advancements in ice models are expected to improve angular resolutions by factors of up to 4 and are applicable to IceCube archival data.

### 1.1.3 IceCube-Gen2 Research and Development

A third high-level goal of the IceCube Upgrade is to serve as a research and development platform for a potential high-energy extension of the IceCube Detector, the IceCube-Gen2 Project. Advances being made for the Upgrade are assessed for their applicability to the Gen2 effort.

Additionally, promising novel in-ice optical module designs will be included in small quantity R&D (“special devices”) deployments on the Upgrade strings. This will allow for a straight-forward evaluation of the detector technologies of potential interest in Gen2 *in situ* and in coincidence with IceCube neutrino and cosmic-ray events. These detector elements include the WOM (Wavelength-shifting Optical Module, a revolutionary step in gaining effective collecting area without increased photocathode size and cost), the FOM (Fiber Optical Module, a similar cost saving strategy but employing fibers deployed into the drill hole), the LOM (Long Optical Module, a more evolutionary module based on the mDOM construction but elongated to fit into a smaller diameter cylindrical housing which could dramatically reduce drilling costs), and test deployments of fiber optic cables to as an alternative to copper wires for communicating with the in-ice electronics.

The new Ice Communications Module (ICM) and the FieldHub surface communications boards are designed with an eye towards Gen2 logistics needs for lower-power in-ice modules and distributed surface electronics. The drill design for the Upgrade is an admixture of the original IceCube Enhanced Hot Water Drill and the design for a fully mobile Gen2 Hot Water Drill. Acoustic pingers are being tested in the Upgrade to understand the analysis of their positioning information in the deep ice for the wider string spacing of a Gen2 detector.

## 1.2 Scientific Requirements<sup>1</sup>

The principal scientific mission of the IceCube Upgrade is the determination of the  $U_{\tau 3}$  element of the PNMS mixing matrix: better than 10% relative uncertainty on the  $\nu_\tau$  normalization and exclusion of no  $\nu_\tau$  appearance at  $10\sigma$  after 1 year of data taking. The Upgrade will also be a powerful instrument for measurement of neutrino oscillation parameters and low-energy searches and secondary goals include: 2% relative uncertainty (68% CL) on  $\Delta m_{32}^2$ ; 12% relative uncertainty (68% CL) on  $\sin^2 \theta_{23}$  if maximal mixing; 6% relative uncertainty (68% CL) on  $\sin^2 \theta_{23}$  if non-maximal mixing; sensitivity to octant of atmospheric mixing angle; excluding maximal mixing at  $3\sigma$ ; determination of the neutrino mass ordering at  $3\sigma$  in 3-8 years (dependent on value of  $\theta_{23}$  and ordering); sterile neutrino limit of  $|U_{\tau 4}|^2 < 0.6$ ; extend neutrino search from solar WIMP annihilation down to WIMP masses  $> 5$  GeV.

High-energy astrophysics goals are as follows: improve angular resolution of *existing IceCube* data 4x in the cascade channel and 2x in the muon channel for commensurate improvement in point source sensitivities and reduction of false alarm rates by 4x; doubling of the astrophysical cascade event rate to 20

---

<sup>1</sup> Also see Appendix 1: Flow Down from Scientific Objectives to Technical Requirements.

2020001-19

per year;  $3\sigma$  observation of cosmic taus after 12 yr. These goals drive requirements on the ice characterization: DOM optical efficiency determination *in situ*  $< 3\%$ ; reduce uncertainties of angular acceptance of IceCube DOMs by a factor of at least 2; measure optical photon scattering in bulk and hole ice to achieve high-energy objectives.

Finally the restart of deep-ice drilling opens up the possibility to field test the functionality and reliability of new sensor instrumentation for the next generation facility and retire risk at an early stage.

### 1.2.1 Management Context of Physical Facilities

The IceCube Upgrade project will be part of the IceCube Neutrino Observatory at the Amundsen-Scott South Pole Station, one of the two dozen major research facilities operated by the National Science Foundation (NSF). Under the NSF Cooperative Agreement PLR-1600823, Management and Operations of the IceCube Neutrino Observatory 2016-2021, the Wisconsin IceCube Particle Astrophysics Center (WIPAC) at the University of Wisconsin–Madison (UW–Madison) oversees the daily, monthly, and annual maintenance of the IceCube facility.

### 1.2.2 Infrastructure Overview

The IceCube Upgrade will take advantage of the existing infrastructure at UW–Madison and the United States Antarctic Program (USAP)-managed South Pole station. UW–Madison maintains dark freezer optical test facilities for characterization of the sensor modules, a high-fidelity single-string implementation of IceCube, and associated computing infrastructure as well as the software repository, hardware spares, and documentation archive for the project. At the South Pole, the existing IceCube Laboratory (ICL) will provide infrastructure, power and computing, to operate the Upgrade strings. USAP contracts with Leidos via the Antarctic Support Contract (ASC) to provide station operations, logistics, medical support, information technology, construction, maintenance, and more at the South Pole station. The Amundsen-Scott South Pole Station is located 841 statute miles inland from McMurdo, at the geographic South Pole, and can accommodate a maximum of 160 people during the austral summer. Two winterover scientists dedicated to IceCube on-site detector operations are among the 40-50 people who remain at the South Pole during the winter. Astronomy and astrophysics are the primary scientific work carried out at the South Pole.

### 1.2.3 Technical Facilities Overview

A high-level overview of the main components of the IceCube Upgrade project are shown in Figure 2. It consists of an enhanced hot water drill (EHWD), the surface junction boxes (SJB) that provide communication from the IceCube Lab (ICL), which houses FieldHubs and power from main station power distribution, the downhole cables and breakout cable assemblies (BCA), and the deep-ice sensor modules. A northern test station will be built at Michigan State University to reproduce a slice of the system from the SJB (Surface Junction Boxes) to the BCA allowing full testing of all components.

2020001-19

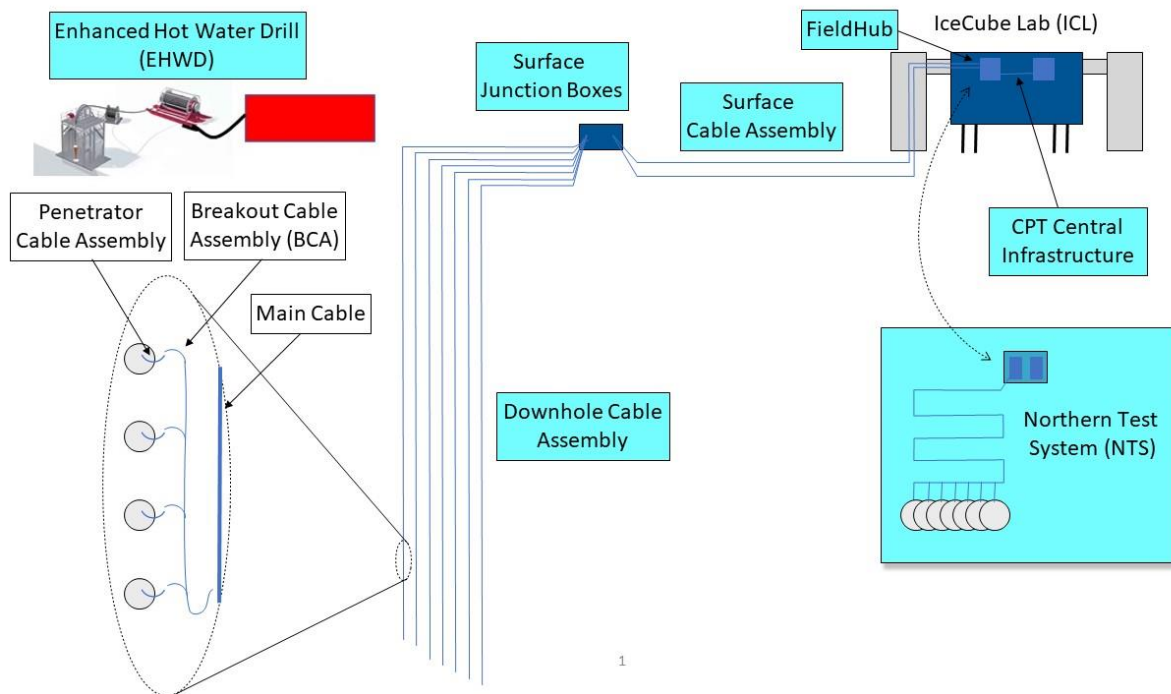

Figure 2: A high-level representation of the IceCube Upgrade.

#### 1.2.4 Technical Facilities Design

The IceCube Upgrade consists of seven detector strings, as illustrated in Figure 3, installed in hot water drilled holes of a 50-cm minimum diameter. The core physics region, for precision neutrino oscillation and tau appearance measurements, consists of 90 optical modules (52 mDOM and 38 D-Egg sensors) over the 275-m vertical distance from 2150-2425 meters below the surface, where the clearest ice for precision measurements lies. At shallower and deeper depths (down to 2600 meters below the surface), a smaller number of optical modules (the mDOMs, D-Eggs, and pDOMs, which are similar to Gen1 DOMs) and calibration sources (POCAM, pencil beam, and radio) are deployed primarily for calibration purposes. The original IceCube Gen1 extends from 1450 to 2450 meters and surrounds these strings. Additional research and development of various types of modules (including the LOM, FOM, and WOM) to study potential sensor technologies for a high-energy IceCube-Gen2 extension are also deployed above the primary physics region.

The deep-ice sensor modules, whether they are PMT-based optical modules, stand-alone calibration devices, or R&D packages, are all connected via breakout cable assemblies to the main downhole cable. Both cable types are derived from IceCube Gen1 experience and the deep ocean industry. All downhole modules additionally communicate to the IceCube DAQ via the IceCube communications protocols (“all modules speak DOM”), receive power over the same communication wire pairs, and host the dedicated electronics to perform those communications (ICM = ice communications module).

The downhole cables terminate in a surface junction box under the snow surface to reduce drifting. Inside, there are connections to horizontal feeder cables that lead back to the IceCube Lab, carrying the data and power on the same wires.

2020001-19

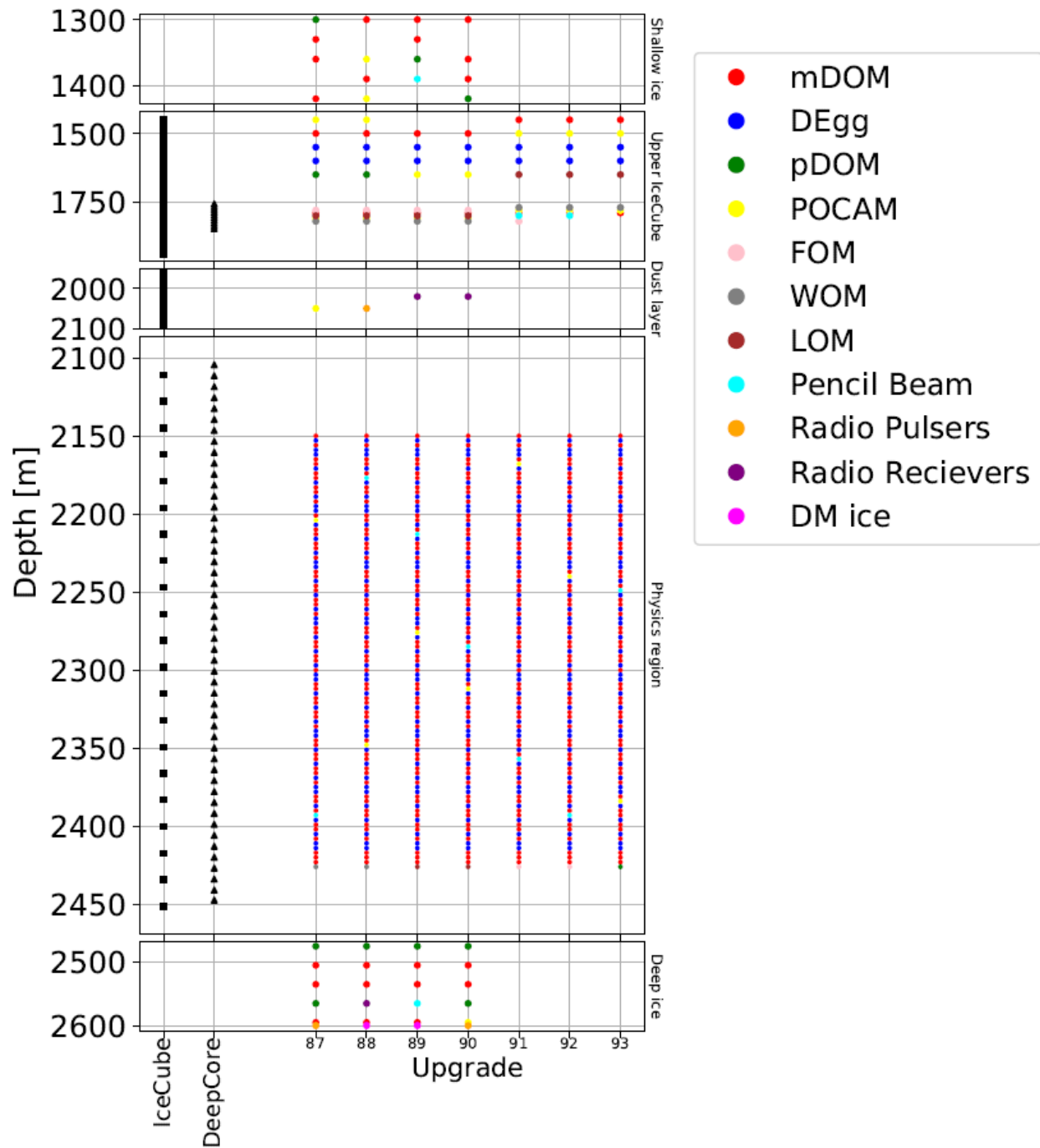

Figure 3: The configuration of the deep-ice sensor modules.

Inside the IceCube Lab, the IceCube Upgrade data is read out in rack-mounted FieldHubs (containing ICMs for the cable communications). The IceCube Upgrade event data is then combined with the IceCube Gen1 data at a low level to permit cross-triggering and full inclusion of the new strings in the data stream: the data appear at the analysis stage as a single, fully integrated experiment. Active calibration devices are controlled by the overall data acquisition system and are interlocked against any unintentional “light in the

2020001-19

detector” during normal data taking. Passive calibration devices and R&D special devices are also managed, with their data routed appropriately.

### 1.2.5 Baseline Documentation

The technical baseline design of the IceCube Upgrade is maintained and documented on the IceCube Upgrade SharePoint site as a directory of design files (configuration management documents, engineering requirements document, engineering design notes, and interface definition documents). The project baseline can be altered using an official change request form along with discussion on the weekly technical board call and the weekly WBS Level 2 manager and change control board call. Change requests are logged and once approved by the project manager are routed to project resource coordination for budget and schedule alterations. This documentation can be accessed and improved by all collaborators. Controlled versions of the documents are created when items are sent to production. Progress is assessed by a mixture of milestones, the EVMS, and the system of reviews, with the design flow through those reviews detailed in Figure 6 and 7.

## 2 Organization

The IceCube Upgrade project is embedded within the existing structure of the IceCube Neutrino Observatory and WIPAC as shown in Figure 4. NSF principal investigators and non-NSF partners contributing significant resources to the project constitute the scientific leadership of the project and ensure that technical decisions such as scope change are made in a manner that preserves the scientific viability of the instrument. IceCube management and operations ensures compatibility with the existing infrastructure. The IceCube Collaboration Board ensures that the project efforts are transparent to the IceCube collaborators.

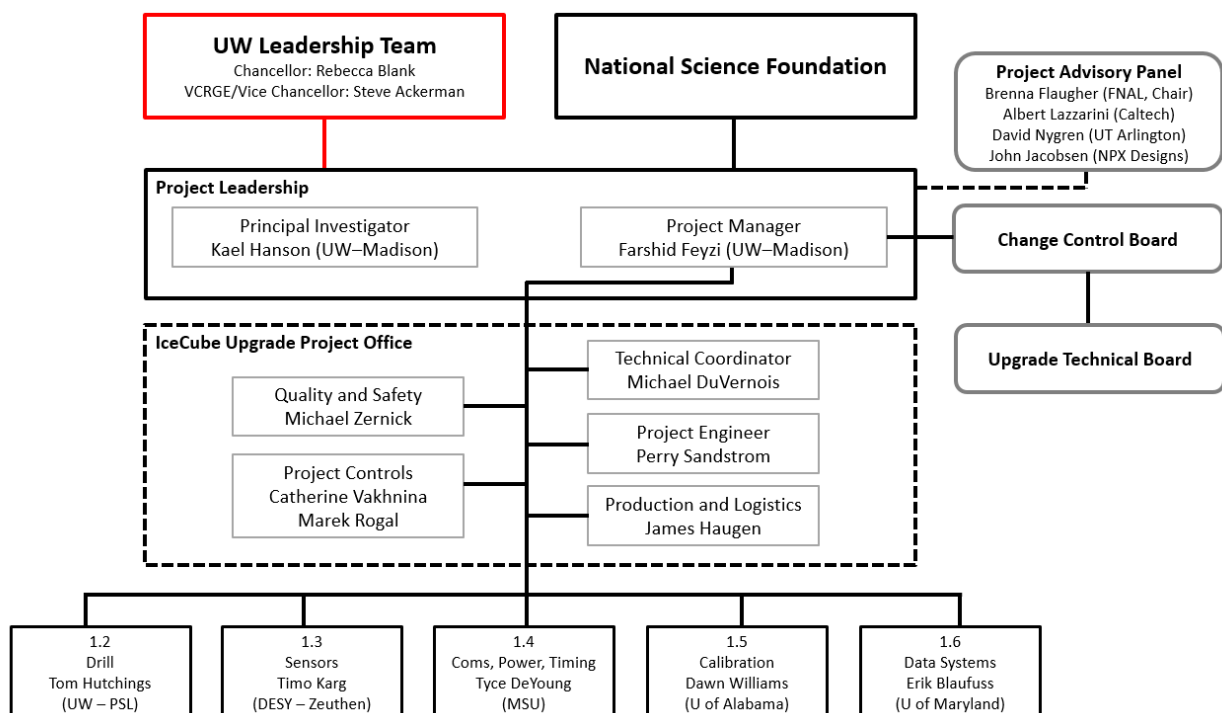

Figure 4: IceCube Upgrade internal organizational structure.

## **2.1 Internal Governance, Organization, and Communication**

### **2.1.1 Project Manager**

The IceCube Upgrade project manager (PM) is appointed by the principal investigator (PI), subject to concurrence of the IceCube Executive Board and approval by UW Leadership and the NSF. The principal investigator holds the PM responsible for technical execution of the project, and the PM oversees and has authority over technical and managerial aspects of the project. The PM establishes the detailed project execution plan, updated yearly, that supports the IceCube Upgrade scientific and technical goals as described in the proposal and in the Cooperative Agreement. In addition, the PM:

- Appoints Level 2 (L2) managers and approves Level 3 (L3) managers
- Establishes engineering standards and requirements
- Develops staffing plans and supervises recruitment and hiring
- Tracks project progress and reports to the PI and NSF
- Develops and monitors subawards
- Chairs the IceCube Upgrade change control board

### **2.1.2 Project Office Senior Staff**

Senior staff includes the technical coordinator, project engineer, quality and safety manager, project controls manager, and production and logistics manager.

The technical coordinator integrates the project scientific, engineering, and quality requirements, providing leadership in these areas and advice to the PM. Additionally, the technical coordinator manages the technical board, including holding weekly meetings on technical status and coordination and directing the project design reviews.

The project engineer oversees the preparation of all key systems documents and approves technical changes. These documents include, but are not limited to, engineering requirements documents (ERD), interface control documents (ICD), verification and testing documents, and procurement specifications.

The quality and safety manager is responsible for project systems quality assurance, document control, and, in conjunction with the project engineer, configuration management. The quality and safety manager also develops and maintains the safety plan and ensures compliance.

The project controls manager is responsible for the overall project schedule and budget as well as earned value reporting.

The production manager works with the quality and safety manager and Level 2 and Level 3 leads of areas involving significant procurements and manufacturing activities to ensure instrumentation is delivered on a schedule that fulfills engineering requirements. The production and logistics manager also provides a nexus for project leads to coordinate with the Antarctic Support Contractor for shipment of instrumentation and deployment of personnel.

2020001-19

### **2.1.3 Level 2 and Level 3 Managers**

WBS Level 2 managers are appointed by the PM and have the authority and responsibility to manage activities and resources within their respective WBS Level 2 elements. Responsibilities include developing engineering requirements, managing budgets and schedules, change requests, and planning and accomplishing work. Level 2 managers define the scope of responsibility of the Level 3 subsystem managers and direct project engineering and project control activities within their areas.

Level 2 managers work principally at their home institution and are an important communication link between the project office and collaboration member institutions. Level 2 managers work in close coordination with both the PM and project office staff. WBS Level 3 managers are appointed by the Level 2 managers, subject to the concurrence of the PM and the technical board. Responsibilities of Level 3 managers include developing engineering requirements, managing budgets and schedules, and planning and accomplishing work.

Level 2 managers are also members of the change control board (CCB). Their responsibilities include: review of change requests by others, controlling the interfaces between subsystems resulting from the change, evaluation of cost schedule and technical impact of change on their own subsystems, and recommendations for approval to the PM. For additional information see Configuration Management Plan.

### **2.1.4 Technical Board**

The technical board is chaired by the technical coordinator and includes the Level 2 and Level 3 managers and technical support staff. The PI and IceCube Collaboration spokesperson are ex-officio members. The technical board meets once per week, via conference call, to discuss project progress, problems, interfaces, potential changes, risk and risk mitigation strategies, and technical requirements, and in person as needed. The technical board also provides recommendations to the change control board and maintains the technical issue tracker.

### **2.1.5 Change Control Board**

The configuration management process, defined in Section 7.2, is used to control changes to the technical, cost, and schedule baselines. A change control board (CCB) decides on these change requests. The CCB is chaired by the PM and consists of the technical coordinator, the project engineer, the quality and safety manager, the project controls manager, the L2 managers, the IceCube associate director for science and instrumentation, and the PI as ex-officio member. The CCB is an executive decision-making body convened when the level of a proposed change to the budget, schedule, or scope of the project demands approval of this body as defined in the Configuration Management Plan.



2020001-19

## 2.2 External Organization and Partnerships

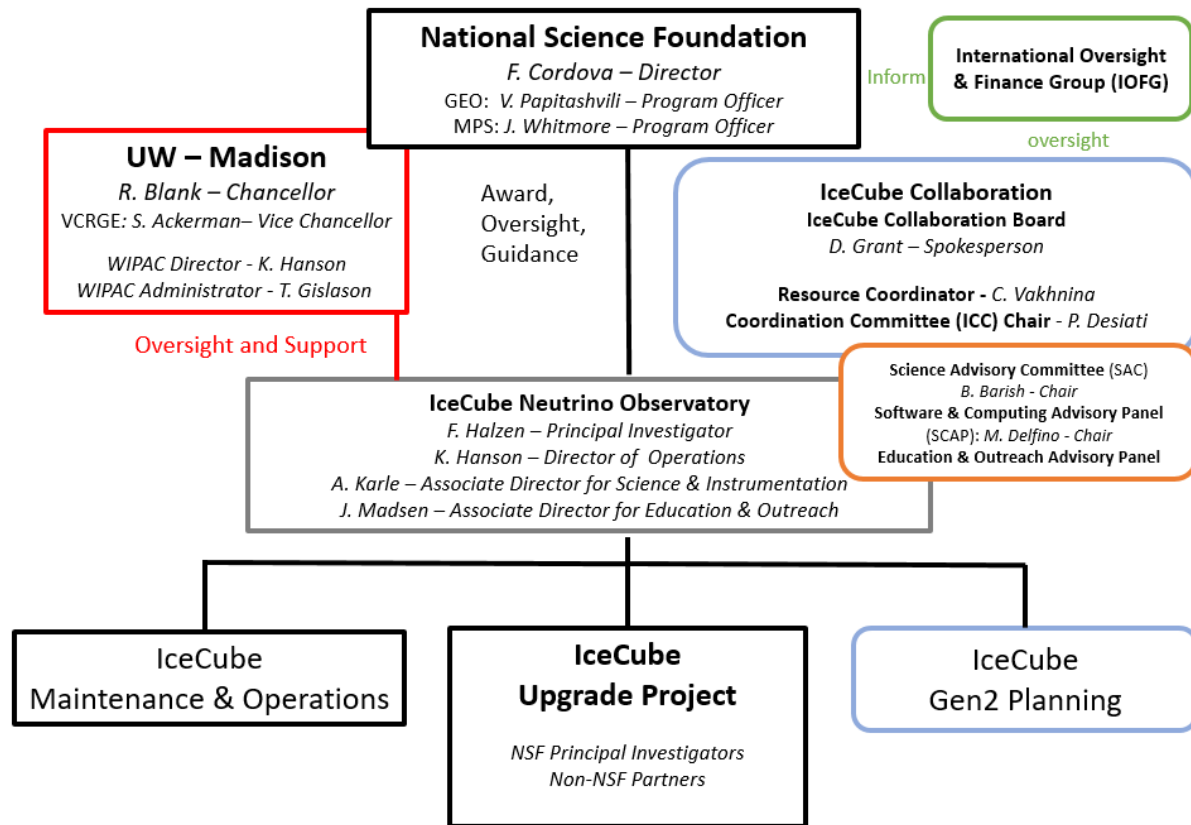

Figure 5: IceCube Neutrino Observatory global organizational structure.

### 2.2.1 National Science Foundation

The NSF is the executive agent responsible for seeing that the IceCube Upgrade meets its baseline requirements of cost, schedule, scope, and technical performance. The NSF has a special role in the IceCube Upgrade because of its host laboratory responsibilities in managing operation of the Amundson-Scott South Pole Station. These responsibilities include safety; physical qualification of project staff; environmental protection; transport of personnel, fuel, and equipment; and the provision of housing, food service, support personnel, logistical support, IT support, and general infrastructure support.

### 2.2.2 International Oversight and Finance Group

The International Oversight and Finance Group (IOFG), already in place for IceCube, provides oversight and financial support for the IceCube Upgrade project. The IOFG organizes annual oversight reviews of the construction project and meets annually to discuss project performance. The IOFG also sets policies for receiving periodic progress reports on all aspects of the project and by all the performers in the project.

### 2.2.3 IceCube Neutrino Observatory

The IceCube Neutrino Observatory is governed by an established and effective collaboration of institutions (IceCube Collaboration) with considerable experience delivering in-kind contributions to the IceCube Gen1

2020001-19

MREFC and steady-state M&O programs. The responsibilities of all collaborating institutions are defined in MoUs executed between UW–Madison, as the project host institution, and the individual collaborating institutions. MoUs are updated twice a year prior to collaboration meetings. MoUs with institutions with in-kind deliverables required for the success of the IceCube Upgrade project include an appendix defining the in-kind deliverables consistent with the IceCube Upgrade project master schedule.

The PM is responsible for signing off on the in-kind deliverables outlined in the MoUs and project schedule. The recipient of the in-kind good or service will confirm when the in-kind deliverable is made, and the Level 2 managers will track delivery dates. The PM uses the tracking spreadsheet to confirm in-kind goods or services were delivered as outlined in the MoUs and project schedule. The tracking spreadsheet is available on SharePoint for the project office to view.

### 2.2.4 Host Institution

UW–Madison is the host institution for the IceCube Upgrade and the home university of the NSF IceCube Upgrade PI. The responsibilities of the host institution include:

- Providing internal oversight for the project
- Appointing the PM (subject to concurrence of the NSF and IceCube Collaboration Board)
- Ensuring that the project office has adequate staff and support
- Ensuring that an adequate management structure is established for managing the project and monitoring progress
- Ensuring that accurate and timely reports reflecting full transparency of the project are provided to the NSF, IOFG, and IceCube collaboration
- Developing subawards with other U.S. collaborating institutions and providing appropriate funding
- Establishing MoUs between UW–Madison and non-U.S. collaborators that define the non-U.S. institutional responsibilities

The IceCube Upgrade project office is headquartered at WIPAC. WIPAC is the primary interface to the university administrative and support systems to coordinate the multiple roles of the university, such as lead and host institution for the IceCube construction project, for IceCube M&O, and for future additions such as IceCube-Gen2. WIPAC provides administrative services such as accounting, purchasing, and human resources, coordinates E&O activities, and collaborates with the largest participating research group. It also supports engineering and computing needs for these projects.

## 2.3 Partnerships, Roles, and Responsibilities

Table 1 shows the national and international partners in the design and construction of the IceCube Upgrade, categorized by NSF-funding status. The roles and responsibilities of each partner are listed.

**Table 1: List of NSF- and non-NSF-funded national and international partnerships with their roles and responsibilities**

| <b>NSF-Funded Institutions</b> | <b>Roles</b>                                      | <b>Responsibilities</b>                                                    |
|--------------------------------|---------------------------------------------------|----------------------------------------------------------------------------|
| UW-Madison                     | Host institution, Project Office, Hot Water Drill | Project management, PDOM production, data acquisition hardware, firmware , |

2020001-19

|                                                                                                       |                                                   |                                                                                                                                                                    |
|-------------------------------------------------------------------------------------------------------|---------------------------------------------------|--------------------------------------------------------------------------------------------------------------------------------------------------------------------|
|                                                                                                       | System, level 1 and 2 management, WBS 1.1 and 1.2 | and software, high voltage electronics, CPT system components, pencil beam calibration module, construction and deployment of drill, deployment of optical modules |
| Michigan State University                                                                             | Level 2 management WBS 1.4                        | Communications, power, timing, detector simulation                                                                                                                 |
| Penn State University                                                                                 |                                                   | Data acquisition, electronics, firmware                                                                                                                            |
| University of Alabama                                                                                 | Level 2 management WBS 1.5                        | Calibration coordination; commissioning                                                                                                                            |
| University of Maryland                                                                                | Level 2 management WBS 1.6                        | Data filtering, software, IceCube integration                                                                                                                      |
| <b>Non NSF-Funded Institutions (see Appendix 4: Contributions in Kind for additional information)</b> |                                                   |                                                                                                                                                                    |
| DESY – Zeuthen, Germany                                                                               | Level 2 management WBS 1.3                        | mDOM production, data acquisition electronics, cables                                                                                                              |
| Karlsruhe Institute of Technology                                                                     |                                                   | Photomultiplier tubes (PMTs) acquisition                                                                                                                           |
| Universität Münster, Germany                                                                          | Level 3 management WBS 1.3.1                      | mDOM mechanical design and integration                                                                                                                             |
| Tech. Univ. of Munich, Germany                                                                        |                                                   | Precision Optical Calibration Module (POCAM)                                                                                                                       |
| Sungkyunkwan University, South Korea                                                                  |                                                   | In-module camera system                                                                                                                                            |
| Chiba University, Japan                                                                               | Level 3 management WBS 1.3.2                      | Optical sensors, D-EGG design, integration, and production                                                                                                         |
| Michigan State University (in-kind)                                                                   |                                                   | mDOM production                                                                                                                                                    |
| Rheinisch-Westfälische Technische Hochschule Aachen                                                   |                                                   | PMT characterization and acceptance testing                                                                                                                        |

## 2.4 Education and Outreach

The IceCube Upgrade project is headquartered at WIPAC, which maintains a staff responsible for education, outreach, and communications for all hosted projects. Other institutions contribute effort and resources with support from WIPAC, such as by hosting high school students for internships and IceCube Masterclasses. Print and web resources including videos for the IceCube YouTube channel are produced to highlight significant results and promote activities through social media platforms, including Twitter, Instagram, and Facebook.

## 3 Design and Development

The design process for the IceCube Upgrade is guided by an overall philosophy of keeping as much IceCube heritage hardware, design, and engineering as possible while also improving on the science returns. Therefore, infrastructure items such as the cable systems remain largely unchanged, while the optical modules that detect the incoming photons are being redesigned to increase performance and explore options for IceCube-Gen2 sensors. Successful, robust segments from the IceCube Gen1 data acquisition system remain the same, including the IceCube nanosecond timing system (RapCal) and general communications and power structures.

### 3.1 Project Design Planning

The design of the hardware, software, and procedures for the IceCube Upgrade is hosted by the IceCube project office at WIPAC in close coordination with the WBS L2 managers and the co-PIs of the funded effort. The project office includes individuals with expertise from IceCube Gen1, the Pierre Auger Observatory, the HAWC Observatory, and NASA balloon experiment construction efforts.

The project office provides project management plans, including updates to this project execution plan, annual reports, supplier qualification documentation, configuration and interface control management, and a central repository for this documentation. The previous experience with the extensive IceCube project documentation will guide this effort.

Existing vendor relationships are extremely important for the design success of this project. We maintain regular contact with the two manufacturers of glass high-pressure enclosures for deep ocean (and deep Antarctic drill hole) use, Teledyne Benthos in the United States and Nautilus in Europe, and SEACON who manufactured the feedthrough penetrators for AMANDA and IceCube and processed the breakout connections on the IceCube main cables. These vendors are aware of our design requirements, and we will continue to work with them through to final design.

The project is divided into three stages: design, production, and deployment. Operation will be subsumed into IceCube M&O as described later. The configuration management plan shows the requirements for moving from one design stage to another, up to and including production readiness. The Upgrade project benefits from a significant amount of design work that has taken place from the end of IceCube construction in 2010 to the start of this project. The design process portion of the project is driven by science and

2020001-19

technical requirements along with well-defined interfaces between the optical modules (with significant design work to be done) and the cable system (much more defined at project entry) and between the IceCube Upgrade strings and the existing IceCube Neutrino Observatory.

### **3.1.1 Design Verification**

Design verification involves design reviews, including a final design review with requisite documentation to enter the production stage, as well as requirements satisfaction and device interoperability testing (see Figure 6: The IceCube Upgrade subsystem design flow matrix built on the System Engineering documentation for the Baseline Library and a series of engineering reviews.) The former is the responsibility of the WBS Level 2 leads, and the latter falls under the northern test stand setup. This will be a sufficiently high-fidelity, cold-tested installation of optical modules and in-ice calibration devices, with the downhole cable quad read through the communications, power, and timing (CPT) system (defined later) and input into the IceCube northern test system.

To smooth the transition to manufacturing, early vendor visits for important parts such as cables, photomultiplier tubes, and a third-party industrial partner fabricating optical modules have been conducted. Prototypes will be assessed for reliability, testability, and manufacturability with the engineering for these requirements, as much as possible, provided by the vendors and overseen by the project office. Due to the unique environment of the detector, two kilometers below the South Pole glacial surface, we expect to work closely with the vendors on testing requirements and manage deployment reviews ahead of South Pole field seasons. This includes detailed on-ice operational procedures, contingency plans, safety (equipment and personnel) plans, and structures that allow for field autonomy in real-time decision making.

### **3.1.2 Project Management Structures for the Design Phase**

The WBS structures are in place for the design phase of the project. The WBS includes design elements as deliverables with ultimate responsibility through the L2 leads, the project office, and the co-PIs. The co-PIs, Level 2 managers, and the project office staff (project engineer, quality and safety manager, production coordinator, technical coordinator, PCMS manager) make up the L2 oversight group for the project, which will manage design scope changes and interface control documents as well as engineering change requests in the latter phases of the project.

2020001-19

| Description of Instrumentation Design Deliverable | Work Product                                                                        | to exit Conceptual Design, you need below | to exit Preliminary Design, you need below | to exit Final Design, you need below | to exit Production Readiness, you need below | Comment                                                                                                                               |
|---------------------------------------------------|-------------------------------------------------------------------------------------|-------------------------------------------|--------------------------------------------|--------------------------------------|----------------------------------------------|---------------------------------------------------------------------------------------------------------------------------------------|
| Description                                       | DSN and CMD                                                                         | Initial                                   | Update                                     | Update and controlled                |                                              |                                                                                                                                       |
| Requirements                                      | ERD                                                                                 | Initial                                   | Update                                     | Update and controlled                |                                              |                                                                                                                                       |
| Block Diagram                                     | slide 4 in DSN                                                                      | Initial                                   | Update                                     | Update and complete                  |                                              |                                                                                                                                       |
| Mechanical Drawings                               | slide 5 in DSN                                                                      | Initial                                   | Update                                     | Update and controlled                |                                              | integrate with Bill of Materials if possible                                                                                          |
| Schematic Circuit Diagrams                        | slide 5 in DSN                                                                      | Initial                                   | Update                                     | Update and controlled                |                                              | if applicable                                                                                                                         |
| Circuit Board Layout                              | slide 5 in DSN                                                                      | Initial                                   | Update                                     | Update and controlled                |                                              | if applicable                                                                                                                         |
| Bill of Materials                                 | slide 5 in DSN                                                                      | Initial                                   | Update                                     | Update and controlled                |                                              | integrate with Mechanical Drawings if possible                                                                                        |
| Interfaces Identified                             | IDD                                                                                 | Initial                                   | Update                                     | Complete                             |                                              |                                                                                                                                       |
| Design Verification                               | VDR                                                                                 | Initial                                   | Update                                     | Update and controlled                |                                              |                                                                                                                                       |
| Investigate alternatives, rationale for design    | Slide 6 in DSN                                                                      | Initial                                   | Complete                                   |                                      |                                              |                                                                                                                                       |
| Risk Assessment                                   | Risk Register                                                                       | Initial                                   | Update                                     | Update                               | Update and current                           | Document changes throughout lifetime of product, apply to project                                                                     |
| <b>Conceptual Design Review meeting</b>           | <b>all documents needed collected in one place accessible via a single URL link</b> | <b>completed Internal Review</b>          |                                            |                                      |                                              | <b>Exit to Preliminary Design with meeting minutes 'approval' or Skip review and proceed with Preliminary Design with L2 / CCB OK</b> |
| Integration Procedure                             | Integration PCR                                                                     |                                           | Initial                                    | Update and controlled                |                                              | must include materials, tools, process, training                                                                                      |
| Test Procedure                                    | Test PCR                                                                            |                                           | Initial                                    | Update and controlled                |                                              | must include materials, tools, pass/fail criteria, process                                                                            |
| Shipping Procedure                                | Shipping PCR                                                                        |                                           | Initial                                    | Update                               | Update and complete                          | must consider all transport modes for delivery                                                                                        |
| Installation Procedure                            | Installation PCR                                                                    |                                           | Initial                                    | Update and controlled                |                                              | if needed                                                                                                                             |
| Production Plan                                   | slide 11 in DSN                                                                     |                                           | Initial                                    | Update                               | Update and complete                          | include labor, sites, rate, equipment, capacity, bottleneck identification, shipping plan                                             |
| Procurement Plan ppt                              | slide 11 in DSN                                                                     |                                           | Initial                                    | Update                               | Update and complete                          |                                                                                                                                       |
| Prototype - Rev 0                                 | actual unit you can hold in your hand + slide 8 in DSN                              |                                           | Initial                                    |                                      |                                              |                                                                                                                                       |
| <b>Preliminary Design Review meeting</b>          | <b>all documents needed collected in one place accessible via a single URL link</b> |                                           | <b>completed Internal Review</b>           |                                      |                                              | <b>Exit to Final Design with meeting minutes 'approval' or Skip review and proceed to Final Design with L2 / CCB OK</b>               |
| Prototype Yield                                   | slide 8 in DSN                                                                      |                                           |                                            | Initial                              | Update                                       | if applicable, include failure analysis, pareto chart, actions to fix                                                                 |
| Prototype - Rev 1 or more                         | slide 8 in DSN                                                                      |                                           |                                            | Update                               | Update                                       | if needed                                                                                                                             |
| Hazard Analysis                                   |                                                                                     |                                           |                                            | Initial                              | Update and complete                          | if needed                                                                                                                             |
| <b>Final Design Review meeting</b>                | <b>all documents needed collected in one place accessible via a single URL link</b> |                                           |                                            | <b>completed External Review</b>     |                                              | <b>Exit to Production Readiness with meeting minutes 'approval'. All instrumentation MUST have an external Final Design Review.</b>   |
| <b>Production Readiness Review meeting</b>        | <b>all documents needed collected in one place accessible via a single URL link</b> |                                           |                                            |                                      | <b>completed Internal review</b>             | <b>Exit to Production / Procurement with meeting minutes 'approval'</b>                                                               |

ERD = Engineering Requirements Document; CMD = Configuration Management Document; DSN = Design Status Notes; IDD = Interface Definition Document; See Section 7.4

Figure 6: The IceCube Upgrade subsystem design flow matrix built on the System Engineering documentation for the Baseline Library and a series of engineering reviews.

The required steps for each item to proceed through the checkpoints from project design, production, and deployment stages are detailed. These gateways are controlled by the project office and the technical and change control boards.

### 3.2 Development Budget and Funding Sources

The IceCube Upgrade project is governed by and is managed in accordance to the requirements of the National Science Foundation Major Facilities Guide (MFG). Per guidelines in MFG, the scope of this project includes support for design activities of all major subsystems: drill, sensors, cables, calibration hardware, and computing through project life cycle up to the operation phase. Funding for these activities is integral to the overall project funding profile (see Section 4.6). In addition to NSF funding to support development activities, in-kind contributions from U.S. institutions and foreign funding from Japan, Germany, and South Korea also support these crucial facets of the project.

2020001-19

### 3.3 Development Schedule and Milestones

Schedules of specific design and development activities are listed by WBS category in Table 2 and Table 3. The items below are critical design and development milestones:

- D-Egg preliminary design review (9/2018): review of technical readiness of D-Egg photomultiplier tube, high-voltage components, and pressure vessel subsystems to allow early procurement of materials for approximately 20 D-Eggs to be used as design verification units. Preliminary design review of D-Egg electronics (data acquisition electronics) took place in June 2019. (Successfully passed milestones.)
- D-Egg final design review (11/2019): review final design of entire D-Egg module.
- mDOM preliminary design review (3/2019): review initial mechanical and electronics designs. Early prototype performance (dark noise rate of sensors) as well as evaluation of performance of PMT pulse digitization technology selected.
- mDOM final design review (4/2020): review of final preproduction mDOM sensor. Final design verification results reviewed.
- Verification test of communications, timing, and power delivery on quad representative of cable (12/2019). Test of new sensor communication and time synchronization hardware on cable systems.
- Onboard calibration devices (9/2019): final design review of calibration devices that are internal to sensor modules before sensor production.

**Table 2: IceCube Upgrade project – Level 1 milestones**

| ID | Milestones                                                    | Completion Dates |
|----|---------------------------------------------------------------|------------------|
| 1  | NSF Upgrade readiness review                                  | Mar 2019         |
| 1  | Deploy drill team (8) for recon and fire/life safety upgrades | Nov 2019         |
| 1  | D-Egg final design and production readiness review exit       | Nov 2019         |
| 1  | Start of D-Egg production                                     | Dec 2019         |
| 1  | mDOM final design review exit                                 | Apr 2020         |
| 1  | Upgrade string design complete                                | May 2020         |
| 1  | Main cable assembly production complete                       | Oct 2020         |
| 1  | South Pole 2020 shipment complete                             | Oct 2020         |
| 1  | Start of mDOM production                                      | Jan 2021         |
| 1  | Standalone calibration devices final design review exit       | Jul 2021         |
| 1  | South Pole readiness review                                   | Aug 2021         |
| 1  | South Pole 2021 shipment complete                             | Oct 2021         |
| 1  | EHWD wet test and commissioning and firm drilling complete    | Jan 2022         |
| 1  | Special devices readiness review                              | Feb 2022         |
| 1  | CPT infrastructure systems commissioned in IDF, ICL           | Feb 2022         |
| 1  | Drill readiness review - PSL                                  | Apr 2022         |
| 1  | South Pole readiness review                                   | Sep 2022         |

2020001-19

|   |                                                            |          |
|---|------------------------------------------------------------|----------|
| 1 | South Pole 2022 shipment complete                          | Oct 2022 |
| 1 | Online software ready for deployment in 2022/23 season     | Nov 2022 |
| 1 | SJBs and ICL ready for Upgrade string commissioning        | Dec 2022 |
| 1 | On-Ice drilling readiness assessment and start of drilling | Dec 2022 |
| 1 | 7 Upgrade strings commissioned                             | Jan 2023 |
| 1 | Decommission, retro and store drill equipment              | Feb 2023 |
| 1 | Upgrade project completion report                          | Sep 2023 |

**Table 3: IceCube Upgrade project – Level 2 milestones**

| <b>ID</b>                              | <b>Milestones</b>                                              | <b>Completion Dates</b> |
|----------------------------------------|----------------------------------------------------------------|-------------------------|
| <b><i>Project Office</i></b>           |                                                                |                         |
| 1.1                                    | Start EV reporting                                             | Mar 2019                |
| 1.1                                    | NSF Upgrade readiness review                                   | Mar 2019                |
| 1.1                                    | Quarterly risk registry update                                 | Mar Jun Sep Dec         |
| 1.1                                    | Instrumentation and online systems pre-ship review             | Sep 2021                |
| 1.1                                    | Upgrade project completion report                              | Sep 2023                |
| <b><i>Enhanced Hot-Water Drill</i></b> |                                                                |                         |
| 1.2                                    | Generator 1 overhaul complete                                  | Sep 2019                |
| 1.2                                    | Procure main drill hose                                        | Nov 2019                |
| 1.2                                    | Deploy drill team (8) for recon and fire/life safety           | Nov 2019                |
| 1.2                                    | Procure drill cables                                           | Mar 2020                |
| 1.2                                    | Fuel day tank rebuild complete                                 | Oct 2020                |
| 1.2                                    | Winches and reels complete                                     | Oct 2020                |
| 1.2                                    | Deploy drill team (8) to start replacement/repairs             | Nov 2020                |
| 1.2                                    | Complete drill head rebuild                                    | Nov 2020                |
| 1.2                                    | Deploy drill team (15) for commission, wet test, firm drilling | Nov 2021                |
| 1.2                                    | EHWD wet test and commissioning                                | Jan 2022                |
| 1.2                                    | Drill all 7 firm holes                                         | Jan 2022                |
| 1.2                                    | Drill readiness review                                         | Apr 2022                |
| 1.2                                    | Deploy drill team (30) for drilling and installation           | Nov 2022                |
| 1.2                                    | Drilling start                                                 | Dec 2022                |
| 1.2                                    | Drilling/installation ends                                     | Jan 2023                |
| 1.2                                    | Decommission and store drill                                   | Feb 2023                |
| 1.2                                    | Final drill completion report                                  | May 2023                |
| <b><i>Deep Ice Sensor Modules</i></b>  |                                                                |                         |
| 1.3                                    | Ice comms module and DOMs interface defined                    | Feb 2019                |



2020001-19

|                                                    |                                                               |          |
|----------------------------------------------------|---------------------------------------------------------------|----------|
| 1.3                                                | Decision on mDOM baseline PMT model                           | Feb 2019 |
| 1.3                                                | D-Egg production test complete                                | Feb 2019 |
| 1.3                                                | Start of mass production of ice comms modules                 | Oct 2019 |
| 1.3                                                | D-Egg final design review and production readiness review     | Nov 2019 |
| 1.3                                                | Start of D-Egg mass production                                | Dec 2019 |
| 1.3                                                | mDOM final design review                                      | Apr 2020 |
| 1.3                                                | mDOM production readiness review                              | Jul 2020 |
| 1.3                                                | Start of refurbishment of IceCube DOMs                        | Aug 2020 |
| 1.3                                                | Start of mDOM mass production                                 | Jan 2021 |
| 1.3                                                | Special devices mission review                                | Jan 2021 |
| 1.3                                                | All DOMs ready to ship to Pt. Hueneme                         | Sep 2021 |
| 1.3                                                | Special devices deployment readiness review                   | Jan 2022 |
| <b><i>Communications Power and Timing</i></b>      |                                                               |          |
| 1.4                                                | Penetrators shipped to DOM assembly facilities                | Sep 2019 |
| 1.4                                                | First-run main cable delivered for evaluation                 | Dec 2019 |
| 1.4                                                | NTS dark facility ready for operations                        | Dec 2019 |
| 1.4                                                | FAT driver units (early FieldHubs) for DOM production testing | Dec 2019 |
| 1.4                                                | Main cable assembly production complete                       | Oct 2020 |
| 1.4                                                | Breakout cable assembly production complete                   | Oct 2021 |
| 1.4                                                | Intermediate distribution facility ready for use              | Nov 2021 |
| 1.4                                                | FieldHub final design review                                  | Dec 2021 |
| 1.4                                                | CPT infrastructure systems commissioned in ICL                | Feb 2022 |
| 1.4                                                | FieldHub production complete                                  | Oct 2022 |
| <b><i>Calibration and Characterization</i></b>     |                                                               |          |
| 1.5                                                | Onboard device PDR, determine scope of non-flasher devices    | Apr 2019 |
| 1.5                                                | Module production calibration review August 30                | Aug 2019 |
| 1.5                                                | Final design reviews for onboard devices                      | Sep 2019 |
| 1.5                                                | Onboard devices ready for integration into DOMs               | Nov 2019 |
| 1.5                                                | Preliminary design reviews for standalone devices             | Nov 2019 |
| 1.5                                                | Final design review for standalone devices                    | Jul 2021 |
| 1.5                                                | Standalone devices delivered                                  | Sep 2022 |
| 1.5                                                | Delivery of timing, geometry calibration                      | Mar 2023 |
| 1.5                                                | Array calibration                                             | Sep 2023 |
| <b><i>Data Systems and M&amp;O Integration</i></b> |                                                               |          |
| 1.6                                                | Provide design verification simulation samples                | Feb 2019 |
| 1.6                                                | DAQ/experiment control/OM software interfaces defined         | Jun 2019 |
| 1.6                                                | NTS Upgrade computing infrastructure ready                    | Oct 2019 |

2020001-19

|     |                                                         |          |
|-----|---------------------------------------------------------|----------|
| 1.6 | Provide software development tool support for Upgrade   | Aug 2019 |
| 1.6 | Minimal DAQ/experiment control ready for OM testing     | Oct 2019 |
| 1.6 | Testing DAQ/experiment control ready for FAT testing    | Jan 2020 |
| 1.6 | Core software (IceTray) upgraded to support new sensors | Jul 2020 |
| 1.6 | Provide full as-designed simulation samples             | Jan 2021 |
| 1.6 | Online software ready for deployment in 2022/23 season  | Nov 2022 |
| 1.6 | SPS Upgrade computing infrastructure ready for use      | Jan 2023 |
| 1.6 | Provide full as-built simulation samples                | Jul 2023 |

## 4 Project Definition

### 4.1 Summary of Project Definition

The IceCube Upgrade physical deliverables are approximately 700 optical sensors, and associated calibration devices, deployed along seven instrumentation cables in the deep ice along with the necessary firmware, software, and computing systems required to bring data from these devices into analyzable form in the Northern Hemisphere data warehouse of the IceCube Neutrino Observatory. To realize the deployment of such an array deep in the ice, a massive drill capable of producing 2600-m deep holes in the glacial ice is required. Project success is defined as the delivery of such a drill unit to the South Pole, successful drill operation in producing at least seven deep holes, and deployment of all instrumentation in these holes within the five-year schedule and \$23 million scope of the IceCube Upgrade project.

### 4.2 Work Breakdown Structure (WBS)

The IceCube Upgrade project uses a detailed work breakdown structure (WBS) as the basis for both scheduling and costing. The IceCube Upgrade WBS is divided into six major elements that are detailed to Level 4 in the WBS dictionary. The WBS at Level 3 is graphically shown in Figure 7 below.

2020001-19

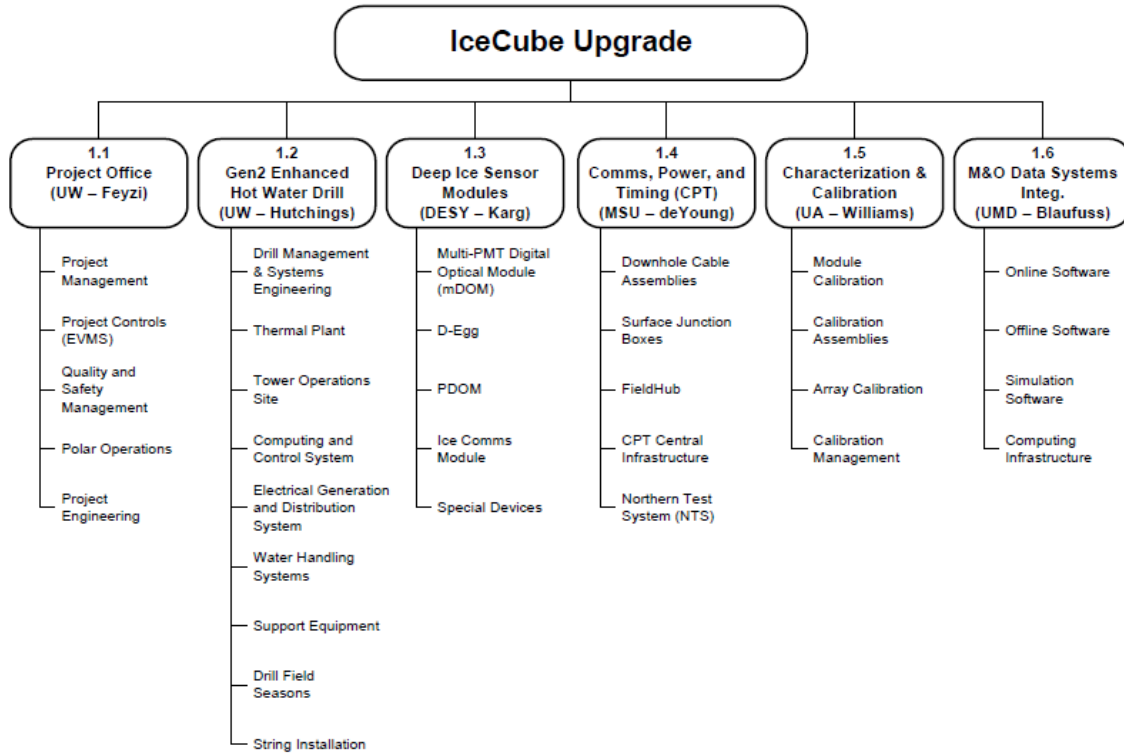

Figure 7 IceCube Upgrade WBS structure at Level 3.

### 4.3 Scope Management Plan and Scope Contingency

The IceCube Upgrade project office is committed to defining consistent cost and schedule baselines, identifying clear milestones, and tracking progress against these references using tools such as earned value management but also through constant communication with project technical leadership. Maximizing project scope given remaining contingency and risk exposure is critical not only to the success of the IceCube Upgrade but also to the longer-term goals of the IceCube-Gen2 observatory. Through proper planning and methodical tracking of risks and contingency versus estimates to complete, down-scoping and up-scoping opportunities will be identified. For example, the current budget supports deployment of 100 optical sensors per instrumentation string; however, the baseline plan is to outfit each string with connectors for up to 126 modules or other devices. This arrangement, for very little investment up front, allows for likely scenarios of up-scoping, that is, adding further instrumentation, given additional resources from smaller international funding agencies. Whereas the timeframe for de-scoping optical module instrumentation should occur in mid-PY2, before large procurements are complete, the decision point for procurement of additional materials for production of supplemental optical module instrumentation is near the beginning of PY4. The throughput from the three module production sites would be capable of supplying 150 sensors, which could then be air shipped to the South Pole in 9/2022 in time for the 2022/2023 deployment season.

2020001-19

#### **4.4 Cost Estimating Plan, Cost Reports, and Baseline Budget**

Budget planning was performed bottom-up utilizing a workbook that lists each WBS task in the project schedule. One budget planning template was used for each L4 element of the schedule. The workbooks contain all of the L4 task details that are captured in the master schedule, i.e., there is a one-to-one correspondence between the schedule tasks and budget entries in the workbook. The template allowed managers to plan labor, materials, capital equipment, travel, and subcontracts for each individual task at the lowest level planned under the L4 element. The cost model workbooks were used to form the overall project budget cost book. The cost model workbooks have been updated with actuals on a monthly basis to show budget and actuals side by side by month.

Labor, materials, equipment, and travel estimates were made based on the tasks in the schedule provided by L2 and L3 WBS managers and updated in a detailed PY2 project re-plan exercise that took place during August and September 2019. When possible, actual names were included. Current labor rates as well as up-to-date fringe and overhead rates are available from the NSF-supported institutions. The level of confidence for the budget based on this approach is estimated by means of a cost uncertainty workbook, as described in section 4.5.2.

As part of the project year 2 detail planning exercise, the cost books and schedule were uploaded to a web-based interactive environment where all level 2 managers and project office have access to the same cost and schedule model. The detail planning exercise consist of breaking the yearly schedule of all tasks to a monthly schedule based on best predictions and plans for the year. Estimated costs for each task were also broken down on a monthly basis. The project office controls the overall cost and schedule with input by level 2 managers. Additionally, and as part of the detail planning, cost uncertainty for each element is reviewed and updated based on better estimates of labor and purchased items. The cost uncertainty for the year, and remaining risk exposure, are then used to arrive at the needed amount of contingency for the year.

#### **4.5 Budget Contingency**

Contingency has been estimated as arising from one of two sources: (a) risks (or opportunities) identified by the technical and managerial project leads and (b) cost uncertainties (“known unknowns”) which occur due to the maturity level of the project planning. Estimates for both sources were constructed using input from subject matter experts with previous experience in the construction of the IceCube MREFC project, using proven, successful budgeting methodologies to effectively and efficiently account for contingency.

##### **4.5.1 Risk Register**

The derivation of the contingency contribution from sources in category (a) above is captured in the IceCube Upgrade Risk Register.

##### **4.5.2 Cost Uncertainty**

The second component of the budget contingency arises from unknowns in the planning model: the degree of reliability of cost estimates of equipment and labor. This was computed using the “IceCube Upgrade Cost Uncertainty Workbook.” The methodology there is as follows: the project cost is broken down into WBS L3 elements. Uncertainties arising from level of maturity of technical, cost, and schedule estimating within that WBS element are assigned a factor, called “risk factors” in the workbook. These factors are described in Table 6.

2020001-19

**Table 4: Cost uncertainty risk factors**

| Factor | Technical                                                                                             | Cost                                                                                                     | Schedule                                       |
|--------|-------------------------------------------------------------------------------------------------------|----------------------------------------------------------------------------------------------------------|------------------------------------------------|
| 1      | Existing design/approach and off-the-shelf hardware/tools                                             | Off-the-shelf or catalog item/existing service                                                           | Not used                                       |
| 2      | Minor modifications to an existing design/approach                                                    | Vendor quote from established drawings/well-defined service                                              | No schedule impact on any other item           |
| 3      | Extensive modifications to an existing design/ approach                                               | Vendor quote from partial design sketches/service concept                                                | Not used                                       |
| 4      | New design/approach for existing product/service                                                      | In-house estimate for item/service currently produced/provided                                           | May delay completion of non-critical path item |
| 6      | New design/approach for new product/service                                                           | In-house estimate for item/service not currently produced/provided, but related to existing capabilities | Not used                                       |
| 8      | New design/approach for innovative product/service based on existing technology/business practices    | In-house estimate for item/service not currently produced/provided, with minimal related capabilities    | May delay completion of critical path item     |
| 10     | New design/approach for innovative product/service dependent on new technology/evolutionary change    | Top-down estimate from analogous programs                                                                | Not used                                       |
| 15     | New design/approach for innovative product/service requiring advanced technology/revolutionary change | Management/engineering judgment                                                                          | Not used                                       |

In addition, a risk percentage is assigned to each of the technical, cost, and schedule, according to Table 7.

**Table 5: Risk percentage for cost uncertainty**

| Category  | Condition                                                     | Risk Percentage |
|-----------|---------------------------------------------------------------|-----------------|
| Technical | Design/approach concerns only                                 | 2%              |
|           | Design/approach and manufacturing/resource concerns           | 4%              |
| Cost      | Material cost concern, only                                   | 1%              |
|           | Material cost and labor rate/ramp down concern                | 2%              |
| Schedule  | Activity required to complete construction of IceCube Upgrade | 1%              |
|           | None of the above                                             | 0%              |

The contingency is computed following the formula:

2020001-19

$$C = \sum_i f_i \times p_i$$

where the index  $i$  refers to the technical, cost, and schedule coefficients,  $f_i$  is the associated risk factor, and  $p_i$  is the associated risk percentage. The resulting number, in the range of 0.0 to 0.98, is then multiplied by the WBS cost element and summed to form the total project cost uncertainty.

#### 4.6 Funding Profile

Anticipated funding profile per Cooperative Agreement (CA) is as shown in Table 9. The contingency allocation per year is also listed.

**Table 6: Anticipated total funding profile and contingency allocation**

|                        | YEAR1              | YEAR2              | YEAR3              | YEAR4              | YEAR5              | TOTAL               |
|------------------------|--------------------|--------------------|--------------------|--------------------|--------------------|---------------------|
| Baseline               | \$4,066,527        | \$5,130,419        | \$3,641,504        | \$3,604,047        | \$3,685,016        | <b>\$20,127,513</b> |
| Contingency            | \$664,979          | \$575,002          | \$362,229          | \$464,748          | \$788,853          | <b>\$2,855,811</b>  |
| <b>Projected total</b> | <b>\$4,731,506</b> | <b>\$5,705,421</b> | <b>\$4,003,733</b> | <b>\$4,068,795</b> | <b>\$4,473,869</b> | <b>\$22,983,324</b> |

#### 4.7 Project Year Detail Planning Process

At the end of each project year, detail planning for the next project year is conducted. Actual costs for prior year, detail plan for upcoming year and projected cost for future years are compared with obligated and anticipated funds in order to plan the upcoming year work. Plans for upcoming year are adjusted to fit within the project obligated amount.

In addition remaining risks and remaining cost uncertainty are compared with remaining contingency. At the time of detail planning any change in contingency, whether it results in a decrease or increase in contingency, are evaluated and communicated to NSF. The process for contingency use and approval will follow the provisions of the Cooperative Agreement and Major Facilities Guide.

##### 4.7.1 Project Year Two Detail Planning

For project years 1 and 2, obligated funds are as listed in Table 10.

**Table 7: Obligated funding for project years 1 and 2**

|              | YEAR1              | YEAR2              | Total               |
|--------------|--------------------|--------------------|---------------------|
| Baseline     | \$4,066,527        | \$5,130,419        | \$9,196,946         |
| Contingency  | \$664,979          | \$575,002          | \$1,239,981         |
| <b>Total</b> | <b>\$4,731,506</b> | <b>\$5,705,421</b> | <b>\$10,436,927</b> |

The preliminary need for contingency for project year 2 is listed in Table 12. Per project policy, the respective Level 2 managers will issue change requests for these items for NSF and management approval.

2020001-19

Approval will be based on performance for labor and based on actual cost for pre-approved capital expenditures. The project scope will not be unchanged.

**Table 8: Project year 2 anticipated change request list for contingency use**

| Change request                 | WBS | Amount    | Justification                                                                                |
|--------------------------------|-----|-----------|----------------------------------------------------------------------------------------------|
| Project controls, safety       | 1.1 | \$235,000 | Addition of project controls specialist per recommendation, safety                           |
| Cable design labor             | 1.4 | \$160,000 | Additional engineering for downhole cables, surface cables and junction boxes in lieu of IDF |
| Penetrator prototypes          | 1.4 | \$64,000  | Additional prototypes needed for cable penetrators                                           |
| System engineering, deployment | 1.1 | \$234,000 | Additional labor for technical coordination                                                  |
| Prototype cameras              | 1.5 | \$10,200  | Prototypes needed for D-Egg cameras and mountings                                            |
| Data systems labor             | 1.6 | \$172,000 | Additional labor needed in PY2 for developing in-OM software systems                         |
| Total                          |     | \$875,200 |                                                                                              |

**Table 9: Analysis of contingency for five-year project plan at start of project year 2**

|                                                | YEAR1        | YEAR2                  | YEAR3                | YEAR4       | YEAR5       | Total        |
|------------------------------------------------|--------------|------------------------|----------------------|-------------|-------------|--------------|
|                                                | Actual       | Detailed plan estimate | Yearly plan estimate |             |             |              |
| Actual cost and current cost estimates         | \$2,925,655  | \$7,084,784            | \$3,737,985          | \$3,311,351 | \$3,053,838 | \$20,113,613 |
| Contingency allocation per funding profile     | \$664,979    | \$575,002              | \$362,229            | \$464,748   | \$788,853   | \$2,855,811  |
| Contingency drawn in previous year             | \$11,644     |                        |                      |             |             |              |
| Contingency accumulated                        | \$653,335    | \$1,228,337            |                      |             |             |              |
| Approximate contingency draw in current year   |              | \$875,200              |                      |             |             |              |
| Remaining contingency at end of current year   |              | \$353,137              |                      |             |             |              |
| Contingency accumulated at end of future year  |              |                        | \$715,366            | \$1,180,114 | \$1,968,967 |              |
| Remaining total contingency at the end of year | \$2,844,167  | \$1,968,967            | \$1,968,967          | \$1,968,967 | \$1,968,967 |              |
| Estimate to complete at start of year          | \$20,113,613 | \$17,187,958           | \$10,103,174         | \$6,365,189 | \$3,053,838 |              |

Table 9 shows the full project plan based on actual expenditures in year 1, detail monthly planning of year 2 and yearly planning of years 3, 4 and 5. The plan represents the result of the rolling-wave yearly planning process. The contingency draw anticipated for project year 2 is based on detail planning and better project definition between the time of cooperative agreement and the time of project year 2 detail planning in August-October 2019.

**Table 10: Analysis of contingency requirement**

|                                                                         | YEAR1       | YEAR2       | YEAR3       | YEAR4       | YEAR5       |
|-------------------------------------------------------------------------|-------------|-------------|-------------|-------------|-------------|
| Cost estimate uncertainty per year                                      | \$0         | \$223,883   | \$474,132   | \$284,535   | \$342,438   |
| Remaining risk exposure at start of year                                | \$1,252,465 | \$1,026,605 | \$965,689   | \$965,689   | \$940,845   |
| Contingency requirement: remaining risk plus remaining cost uncertainty | \$2,577,453 | \$2,351,593 | \$2,066,794 | \$1,592,662 | \$1,283,283 |

Table 10 shows the current cost uncertainty and risk analysis results. Cost uncertainty for project year 1 is zero due to the fact that it is finished. Cost uncertainty for project year 2 is based on detail planning of the year and takes into account detail labor planning and issuance of drill hose purchase contract. Cost uncertainties for years 3, 4 and 5 are as originally estimated. Remaining risk exposure is based on quarterly update of risk analysis and represents the current estimate of remaining risk at the start of each project year. Remaining risk exposure at the start of a year and remaining cost uncertainty values for that year and future years are added to arrive at the required contingency amount for that year, e.g. for year 2:  $\$2,351,593 = \$1,026,605 + \$223,883 + \$474,132 + \$284,535 + \$342,438$ .

#### **4.8 Baseline Schedule Estimating Plan and Integrated Schedule**

The project master schedule baseline was assembled from individual L2 schedules. The schedule comprises NSF and non-NSF deliverables as the project office is charged with organizing the schedule globally. WBS elements down to Level 4 correspond to physical deliverables of the project. Below Level 4 the schedule items are either for development phases of elements that are less well defined or for specific tasks on complex critical deliverables such as sensors and string instrumentation. The tasks in these areas were informed by the instrumentation build-out of the IceCube construction project.

Scheduling tools are used for planning a detailed schedule for all years of the project. They are also used to track percent completion by task level and subsequent progress against the plan. The project office maintains control of the master schedule and update actual progress as reported by L2 managers once per month as part of the NSF reporting cycle. The schedule will be used for planning and illustrating progress against plan and interdependencies between tasks.

### **5 Staffing Plan**

This section includes key IceCube Upgrade project office staff and their responsibilities and qualifications.

#### **5.1 Project Manager**

The PM is the central figure coordinating and making decisions on all technical and managerial aspects of the project execution. The complexity and risks associated with this project require the following qualifications from this individual: experience as PM or deputy with a construction project of similar scale



2020001-19

and similar technical background; engineering or scientific background with advanced degree; familiarity with NSF and/or DOE project organization and technical progression; and experience working in a project environment distributed across multiple institutions and working with multiple funding sources, possibly international.

Farshid Feyzi was designated as the Upgrade project manager effective July 1, 2019. Feyzi has extensive experience managing large instrumentation projects funded by DOE and NSF with multiple national and international collaborators, including overseeing the construction of the IceCube Gen1 hot-water drill.

## **5.2 Project Controls Manager**

The project controls manager is Catherine Vakhnina, who has served in a similar role for IceCube maintenance and operations for seven years. Her qualifications include experience with project planning, budgets, and schedules; resource coordination; MoU and subaward management and tracking; performance tracking; and knowledge of earned value management. She has a master's degree in business and possesses PMP certification.

## **5.3 Technical Coordinator**

Michael DuVernois is the technical coordinator. He has held scientific and technical leadership roles in both NSF- and NASA-supported projects. These include the Pierre Auger Observatory, the High-Altitude Water Cherenkov (HAWC) Telescope, the ANITA, HEAT, CREAM, and CREST balloon payloads, and High Energy Telescope (HET) on the Ulysses spacecraft. He has led fieldwork at McMurdo, the South Pole, high-altitude sites in Mexico and Chile, and remote sites in Argentina, the US, and Canada.

## **5.4 Project Engineer**

Perry Sandstrom serves as project engineer. He has been a member of the IceCube project for many years, serving in a similar capacity during the construction and operations phases.

## **5.5 Production Coordinator**

James Haugen serves as production coordinator, providing logistics support and acting as liaison to the Antarctic Support Contractor. He has been a member of the IceCube project for many years, serving in a similar capacity during the construction and operations phases.

## **5.6 Safety and Quality Manager**

Michael Zernick has been hired as the safety and quality manager. Zernick worked as safety officer during IceCube construction.

## **5.7 Project Controls Specialist**

Marek Rogal started as the Project Controls Specialist. Principal duties are: development and maintenance of master schedule and cost database, communication with cost account managers to track project progress, generation of earned value metrics for project monthly reports, and assisting with cost and schedule planning.

## 6 Risk Analysis and Mitigation

This process is documented in *IceCube Upgrade Risk Management & Mitigation Plan*, document # 2019-004.

## 7 System Engineering and Configuration Control

### 7.1 System Engineering Plan

The primary scope of the IceCube Upgrade system engineering team is to define, establish, and control individual subsystem requirements and interface requirements between subsystems. System engineering is responsible for incorporating the various technical contributions into an integrated system through interface design and specification, modeling, and simulations.

### 7.2 Configuration Control Plan

Configuration control of the IceCube Upgrade requires an approach that allows tasks to be performed by a distributed network of collaborators while at the same time providing the necessary controls to ensure that the system configuration is maintained. The project office establishes the requirements for configuration management. Those requirements flow down to the organizations performing the actual tasks through MoUs and/or statements of work. Configuration requirements are reviewed and approved in accordance with the configuration management plan. It is the responsibility of each organization to use its existing configuration management system (if adequate) or institute one that complies with the IceCube configuration management requirements. Conforming to the configuration management plan is the responsibility of the Project Engineer and is monitored by the quality and safety manager.

A PY1 deliverable of the IceCube Upgrade project office is the configuration management plan (CMP). This plan ensures that the schedule, budget, and performance impacts of changes to the baselines are tracked and recorded. It also ensures that complete and accurate descriptions of the project's technical, schedule, and cost baselines are developed and maintained. The CMP provides:

- A mechanism for establishing the baseline
- A process for identifying and managing changes
- A method to verify proper implementation
- Reports to notify the change to others who have an interest
- Records of the change for historical reference
- A central document library and document control system for project documentation including drawings, requirements documents, interface control documents, and manufacturing records

### 7.3 Quality Systems and Safety

Quality systems for the IceCube Upgrade project are a vital component in the delivery of successful hot-water drilling and instrumentation deployment. A quality and safety manager, who has the technical skills and background to address the issues in the context of the IceCube Upgrade, manages the effort. Quality systems, as applied to the IceCube Upgrade project, encompass nonconforming materials, incoming

2020001-19

inspections, document control, audits, and corrective and preventive actions. It is an integral part of the design, procurement, fabrication, and deployment phases. The program objective is to ensure the completion of a high-quality, reliable, and advanced detector. Achieving this goal requires all project participants to employ accepted and sound engineering practices and to comply with all applicable procedures. Quality functions are integral to the entire IceCube Upgrade team, allowing for a seamless approach and the institutionalization of quality into the project. The document “IceCube Upgrade Quality Plan” describes the details of the quality systems program.

The IceCube Upgrade environmental safety and health (EH&S) program has the following specific objectives:

- To prevent personnel injury or loss of life during all phases of the IceCube Upgrade project
- To prevent environmental contamination during the construction, testing, or operation of IceCube
- To prevent damage to equipment caused by accidents during all phases of the project
- To comply with all applicable federal, state, and local laws, rules, and regulations
- To comply with safety protocols on the field as established in cooperation with the support contractor

The quality and safety manager administers the EH&S program with the full support of the PM. The safety policy lays out a foundation for project development and operations intended to establish a culture where the safety and health of personnel and equipment is of paramount concern, individuals are empowered, and management encourages and promotes safety in all elements of the project. Details of the IceCube Upgrade EH&S program are in the document “IceCube Upgrade Safety Manual.” Details of the safety planning for each season at the South Pole are found in the IceCube Upgrade safety plan.

Design and implementation of safety equipment are the responsibility of the IceCube Upgrade safety manager in concurrence with NSF and support contractor. In the areas of drilling and deployment, the safety equipment are as designed and implemented during IceCube Gen1. Any modifications to design and implementation of safety equipment will go through the change control process and with approval requirements per Project Configuration Plan.

On an annual basis, the quality and safety manager reviews the safety plan with all of the IceCube personnel who are deploying that season to the South Pole. This review is a part of the comprehensive deployment team training in August prior to deployment.

The IceCube Upgrade project reviews both the quality plan and the safety plan on an annual basis to incorporate revisions stemming from lessons learned or other revision sources.

#### **7.4 Design Baseline Documentation**

The baseline content is stored in a documentation database instance in SharePoint which allows for collaboration-wide contributions, editing, and reviewing. This is then moderated with a full available history of edits, and a document control system which allows the uncontrolled documents held in common by the collaboration into controlled and approved documents. The transition from uncontrolled to controlled documentation is managed by the Quality Assurance Engineer with approvals from Tech Board discussions and internal engineering reviews.

2020001-19

System engineering is handled through the use of multiple defined document types for each baseline configuration item. Configuration items are stored hierarchically from the “IceCube Upgrade” level down to low level hardware and software items such as cable assemblies, electronics boards, and glass pressure housings. Each configuration item has the following documents:

- Configuration Management Document (CMD) : Links the hierarchy of configuration items and bill of materials for bottom level configuration items
- Engineering Requirements Document (ERD): Details the engineering requirements, and often how those requirements hook to science requirements, how the requirement is verified, and how the requirement was set.
- Interface Definition Document (IDD): Covers the interfaces (electrical, mechanical, optical, etc.) between this configuration item and any other configuration items affected.
- Design Status Document (DSN): This presentation formatted document carries the current status of the design, photos of parts, links to manufacturers and software repositories as needed, and generally forms an evolving repository of documentation of the design process of the individual configuration item.

This configuration management system was built up this first year of the project and is well-populated with the systems and subsystems of WBS 1.3, 1.4, 1.5, and 1.6. The drill documentation is handled separately as the requirement of broad, international editing of the documents are not required for the drill. These documents are owned by the respective L3 (or lower) managers until the documents are controlled via successful review.

The engineering requirements have been derived from the higher-level science requirements via the PEP science-engineering requirements flow-down matrix filtered through the hardware experiences from the Gen1 IceCube construction. This is especially important for the extreme environment of the deep, cold glacial ice of South Pole.

## 8 Acquisitions and Procurement

### 8.1 Major Acquisitions

Major acquisitions (equipment with costs in excess of \$250k) with estimated time frames are:

- Drill WBS 1.2: the drill hose used by the IceCube drill is manufactured by IVG for a cost of \$1,067,000. It is a COTS, non-critical-path item that originally envisioned to be purchased early in PY2 for shipment to the South Pole in late summer of 2021. The order actually was placed September 2019 after discussion with IVG.
- Sensors WBS 1.3: photomultiplier tubes, both the 3" used in the mDOM and the 8" in the D-Egg are major capital acquisitions and are currently both expected to be sourced from Hamamatsu, totaling \$2.3M and \$0.7M, respectively, but they are not envisioned to be supported by NSF funding. Procurement for D-Egg 8" PMTs is considered low risk without viable alternatives and

2020001-19

will proceed following a successful review. The 3" PMT procurement was initiated by KIT September 2019 following review and possible alternate selection qualification.

## 8.2 Subcontract Management

Each participating U.S. institution has a subaward with UW–Madison (the host institution) that defines the cost, schedule, and performance requirements for the planned participation. The budget provides funds to UW–Madison, which then distributes them through subaward agreements to Michigan State University, Pennsylvania State University, the University of Maryland at College Park, and the University of Alabama at Tuscaloosa. In general, funds are divided such that the institution responsible intellectually for a specific deliverable, *e.g.*, a piece of equipment, is also responsible monetarily for it, and that institution's purchasing system provides the infrastructure for those purchases, ensuring they adhere to federal procurement standards.

The project controls manager is responsible for developing and maintaining the subawards with support from the institutional legal representatives.

## 9 Project Control Plan

A project management control system (PMCS) is maintained to track the budget, schedule, and resources necessary to complete the IceCube Upgrade. The PMCS contains the costs and schedule as well as the scope, resource allocations, work descriptions, the basis of estimates, and the activity-based risk assessment evaluation. The PMCS maintains data in the base year value as well as the then-year costs. The IceCube Upgrade project office has defined consistent cost and schedule baselines built on the foundation of a well-developed work breakdown structure (WBS) for development, implementation and commissioning of the IceCube Upgrade. The schedules include clearly defined milestones against which progress of major tasks is judged. A formal project management control system (PMCS) provides a wide variety of management products for effectively monitoring progress and assessing project health.

### 9.1 Earned Value Management System

The project office began implementing effective cost and schedule tracking tools, analyzing performance, and including this data in monthly reports March 2019. These reports include monthly comparisons of actual versus planned resource use in the categories of total cost, labor cost, non-labor cost, and full time equivalent (FTE) staff utilization. An earned value management system (EVMS) is implemented to comprehensively plan work and objectively assess cost and schedule performance. Cost and schedule data are collected at WBS Level 4 or lower and reports are generated for the total project, WBS Level 2, and WBS Level 3 on a quarterly basis. Summary reports are posted on the web to provide managers outside of UW–Madison with the means to follow the overall progress of the project.

Level 3 managers identify and mitigate risks associated with their tasks and take appropriate corrective action if a task falls behind schedule, consumes more resources than planned, or encounters technical difficulties. They communicate with Level 2 managers and project office staff on a continual basis and provide written quarterly status reports to their respective Level 2 managers.

Monthly status reports include cost, schedule, and technical progress for each active Level 4 WBS element. Data for these reports are generated by technical and financial managers at each participant institution,

2020001-19

submitted via the internet, reviewed and quality controlled by project office staff, and input to a formal project management system. The updated project management system will be used to generate a wide variety of recurring reports for managers at all levels of the collaboration that are timely, internally consistent, and accurate.

Level 3 managers are responsible for continually estimating remaining work on tasks, iterating on the schedule, budget, and requirements for an optimum balance, and communicating results to the project stakeholders. When cost or schedule problems arise, project office personnel will work with the appropriate Level 3 manager, or subcontractor, to correct the problem using the resources currently allocated for the task.

Level 2 managers approve plans, manage resources, and oversee all aspects of subsystem (Level 3) development within their areas of responsibility. They participate in weekly status meetings with the PM and project office staff, serve as primary members of the change control board, and provide written status inputs for monthly reports to the NSF.

If current resources are not sufficient, the Level 2 manager will make a recommendation to reduce the scope of the task, reallocate resources from another task, or apply previously unallocated management reserve funds. If scope is reduced, the PI advises the PM as to whether the proposed change adversely impacts the scientific objectives of the project.

## **9.2 Financial and Business Controls**

Administrative, accounting, IT, and human resources support are provided by the Wisconsin IceCube Particle Astrophysics Center of UW–Madison. The IceCube Upgrade project office is a beneficiary of the robust UW–Madison human resources system and follows its personnel policies and procedures, which include strategies to recruit, develop, and retain a diverse workforce. UW–Madison is committed to hiring the right talent to ensure that the university continues to be a world-class institution of higher education. The university’s goal is to provide opportunities for talented people from all backgrounds to help us maintain a highly productive, welcoming, empowering, and inclusive community. UW–Madison encourages women, minorities, veterans, and people with disabilities to apply for our vacancies. WIPAC will continue to strive to attract outstanding candidates from underrepresented groups.

The IceCube Upgrade will follow all generally accepted accounting principles (GAAP) and Code of Federal Regulations (CFR) Part 200 “Uniform Administrative Requirements, Cost Principles, and Audit Requirements for Federal Awards” as well as comply with all statutory and regulatory requirements. IceCube also adheres to UW–Madison financial policies and procedures, which are designed to ensure compliance. As a recipient of federal government funds, the IceCube Upgrade is subject to audit by federal agencies in addition to its outside independent auditors. As described in section 9.1, the PMCS system will be integrated with the WIPAC accounting system in such a way as to support earned value management and to provide timely performance reports of variances with respect to the baseline project plan. Detailed financial, accounting, and other policies may be found online on UW–Madison website.

2020001-19

## **10 Site and Environment**

### **10.1 Site Selection**

The IceCube Upgrade instrumentation will be installed within the existing envelope of the IceCube neutrino detector at the South Pole. The South Pole environment presents an obvious set of design challenges to overcome, however the successful completion of the IceCube Neutrino Observatory provides a framework to follow.

The IceCube Upgrade will work closely with ASC to mitigate the potential impacts of the extreme cold and low humidity at the South Pole. IceCube Upgrade project management is mindful of the unique environment in the Antarctic and will continue to advise all project participants to follow USAP policies and to work in a proper and safe manner.

### **10.2 Environmental Aspects**

The IceCube Upgrade will follow the guidance as stated in the Comprehensive Environmental Evaluation (CEE) that was prepared by the director of the Office of Polar Programs in 2004 for the original IceCube project. The IceCube Upgrade will work with ASC to compile an intermediate environmental evaluation (IEE) which will branch off from the IceCube CEE and will be focused on Upgrade activities only.

### **10.3 Logistics**

The primary logistical challenges of the project revolve around deployment of equipment and people to the South Pole and the operation of that equipment in support of deploying IceCube Upgrade instrumentation. In addition, logistical challenges are created by the multisite production strategy for deep-ice sensors. The IceCube Upgrade Production Coordinator has successfully worked with the ASC (formerly RPSC) since 2003 to coordinate logistics and resources required to construct and operate the IceCube detector, along with other experiments at the Pole. Requirements will be detailed in the annual submission of the support information package (SIP) each March. The yearly plan will be finalized in September by IceCube Upgrade's concurrence with the ASC-generated research support plan (RSP). IceCube Upgrade logistics will communicate and coordinate with internal and external agencies to ensure the smooth and timely shipment of personnel and equipment to the South Pole for successful startup of activities and work related to the main drilling season in 2022-2023. Logistics will provide other detailed support for ongoing activities to enhance delivery of equipment and the smooth transition of personnel while acting as the central point of contact for quick resolution of logistics discrepancies to ensure a successful drilling season at the South Pole. Detailed logistics plans and strategies will be documented in the "IceCube Upgrade Logistics Plan."

## **11 Reviews and Reporting**

### **11.1 Internal Reviews**

The project office conducts a variety of internal meetings to coordinate work and assess status.

2020001-19

### **11.1.1 Subsystem Technical Reviews**

As subsystem elements progress from preliminary design to final design and on to production readiness, a series of technical readiness reviews will be held to ensure subsystem maturity is consistent with transition to the next phase. Panels for these reviews will comprise primarily internal subject matter experts along with external advisors selected as needed by the technical coordinator. NSF program officers are invited to participate in the reviews, and panel reports will be shared with the collaboration and the NSF.

### **11.1.2 Configuration Control Board Meetings**

Configuration control board meetings are conducted weekly along with the L2 weekly updates to review and pass along recommendations on baseline change requests to the PM.

### **11.1.3 Project Advisory Panel Meetings**

Project advisory panel meetings are held annually, and on an ad hoc basis as needed, to review project execution issues and recommend actions to improve efficiency and reduce risk.

### **11.1.4 Science Advisory Committee and Software & Computing Advisory Panel Meetings**

The existing IceCube M&O advisory committee meetings are held annually or on an ad hoc basis and will have an additional agenda item to review and make recommendations on the IceCube Upgrade scientific goals, computing needs, and other matters that may affect the scientific activities of the neutrino observatory.

## **11.2 External Reviews**

### **11.2.1 IceCube International Oversight and Finance Group Meetings**

The International Oversight and Finance Group meets annually to approve MOUs or changes to MOUs and to review the current status of the IceCube project. The IOFG reviews and endorses the annual work plan, including budget, schedule, and technical objectives.

### **11.2.2 NSF Annual Reviews and Site Visits**

The NSF conducts annual reviews in the fall of each year ahead of the deployment season. The review evaluates the following items:

- Annual bottom-up cost estimate
- Schedule and technical progress
- Management
- Annual readiness to proceed with deployment season

The NSF also conducts site visits and reviews in the spring of each year, including an external panel. The review evaluates the following items:

- Overall project status and business systems review
- Project technical progress and performance against baseline
- Technical achievements of field season



2020001-19

Appendix 2 shows the current plan for upgrade project reviews. IceCube Maintenance and Operations reviews are also shown.

### **11.3 Reporting**

The project office prepares monthly performance reports and an annual report. These reports are distributed within the IceCube project organization and collaboration, host institution, various IceCube advisory and oversight committees, and to the NSF.

#### **11.3.1 Monthly Performance Reports**

Monthly reports are submitted to the NSF. This report is prepared in accordance with the Cooperative Agreement and consists of a summary of work accomplished during the reporting period. The monthly report includes major scientific and technical accomplishments, an assessment of current status against the cost and schedule baselines, and an overview of current or anticipated problem areas. This report also includes management information such as changes in key personnel and other actions requiring NSF/IOFG notification.

#### **11.3.2 Annual Reports**

An annual report is prepared and submitted to the NSF and the IOFG. The annual report contains:

- A summary of major technical accomplishments compared to the proposed goals of the period
- Financial and schedule status information similar to that given in the monthly report
- A summary of any current problems and favorable or unusual developments
- A summary of work to be performed during the following year

#### **11.3.3 Earned Value Management System (EVMS) Report**

EVMS reports are updated monthly for discussion by the technical board. Actual costs are “estimated actuals” for the report month. These estimated actuals consist of some actual values for the early portion of the month (the first two weeks or so) and estimates for the last half of the month. To formulate earned value, L2 managers estimate percent complete at the lowest task level in their schedules. This information is collected by the project office for roll-up and reporting to the NSF and other stakeholders. An EVMS report consists of data sheets for each L2 that shows actual, earned, and planned values at L3. A summary sheet that rolls up overall earned value at L2 along with cost and schedule variance is compiled and reported in the monthly report.

## **12 Transition to Operations**

The existing IceCube Neutrino Observatory provides a natural framework into which the IceCube Upgrade, once operational, will transition. Sensor hardware, firmware, and software systems are designed with the IceCube interface taken into consideration to permit an efficient incorporation of the additional instrumentation in the current operational infrastructure requiring only minimal increase in operations scope. The Upgrade detector elements will pass from the Upgrade Project to the ICNO after successful drilling, deployment of the sensors, freeze-in, and the initial commissioning of the detector systems. See 13.1 for a discussion of the definition of success of these systems. This will all occur in early 2023.

2020001-19

Calibration will continue afterwards, both to understand the Upgrade systems and to better calibrate the Gen1 IceCube, but the operations will be completely subsumed into normal ICNO operations.

We have considered how to incorporate the first analyses of the IceCube Upgrade data, including the important new calibration inputs to the analysis, in the final documents for the project. We will have the calibration goals of the Upgrade fully documented (on improvements both for the Upgrade sensors and for the Gen1 data) going into the commissioning of the new modules, and will deliver preliminary calibration results during the final year of the project. These will not be the final calibrations, but will reflect the importance of in ice calibration as one of the primary goals of the project. In practice these activities will be split between the IceCube Observatory normal operations and the Upgrade calibration team efforts.

## **13 Reliability and Overall Performance of the IceCube Upgrade**

The IceCube Upgrade's unique operating environment and total inaccessibility of major in-ice system elements following deployment place a high priority on careful reliability engineering. The primary reliability engineering analysis for IceCube are based on a "physics of failure" assessment of the factors that introduce stress on system elements, supplemented by statistical analysis of failure rate predictions when meaningful data is available. Available IceCube failure history are examined for insight, and experience from similar systems such as KAMLAND and Super-K will also be utilized where applicable. The goal of the reliability program is to maximize the number of functional sensors in the ice.

### **13.1 Physics, Calibration, and R&D Success Key Performance Parameters**

Success of the project's hardware installation effort is indicated by seven strings of detector modules deployed into >2450-m deep ice boreholes at the South Pole with >95% of the in-ice optical modules (D-Eggs plus mDOMs) functional throughout the science run. (This is similar to the successful Gen1 requirement.) In addition to any that fail completely, individual optical modules are considered to have failed if they have less than 75% nominal acceptance. For calibration success, it is required that >90% of all flasher-to-optical module transmission measurements be performed and that camera imagery exists for both freeze-in and post freeze-in hole ice. R&D modules are likely to have had less strict reliability and manufacturing controls, so for each special device type we would consider module operation a success if some of the modules performed to specification in the ice after freeze-in.

### **13.2 Physics of Failure Methodology**

Physics of failure (PoF) is an approach for the development of reliable products that uses knowledge of root cause failure processes to prevent product failures through robust design and manufacturing practices. The basic premise is that it is equally important to understand how equipment works and how it fails in the environment in which it is expected to operate.

Unlike statistical analysis, which requires a prior database of comparable experience, PoF methods can be applied effectively in unique environments such as IceCube. By carefully understanding the sources, types, and levels of available energy that may cause harm, one can readily identify the system elements most at risk. Applying this insight into how the design interacts with environmental stressors enables a proactive risk response and results in significantly higher reliability.

2020001-19

### **13.2.1 Role of Statistical Analysis**

Statistical analytical methods shall be used as a supplement and extension of PoF reliability analysis whenever appropriate source data is available or can be reasonably developed using probabilistic methods. Failure rate estimates will be made for purposes of system availability estimation using as guides a 95% in-ice module survival and a 15-year life span of the in-ice detector array. Data collected during developmental and production testing will be captured for analysis and predictive value.

### **13.2.2 Failure Modes, Effects, and Criticality Analysis (FMECA)**

Every system element will be examined in terms of possible failure modes and root cause—an activity closely integrated with PoF reliability philosophy and methods. As each failure mode is identified, the anticipated effect is determined and associated with a criticality level. This information is central to reliability modeling activities and to creating designs that are fault tolerant or at least fail gracefully through gradual degradation rather than exhibiting outright loss of functionality.

### **13.2.3 System Modeling**

System modeling tools such as MIL-HDBK-217 and Telcordia (Bellcore) are limited in their direct applicability on a project such as IceCube due to the unique operating conditions but are still useful for generating a baseline model. We will utilize the MIL-HDBK-217 approach to develop a system reliability model that will extend to the component level for critical system elements, in particular the high-voltage generators, and the in-ice module mainboards. This baseline model will be extensively applied during design for reliability allocation and estimation purposes.

### **13.2.4 Failure Review and Corrective Action**

Although failures are always unwelcome, they offer a wealth of information that can be used to modify the design or environment to address the underlying causes of problems. Thorough root cause analysis often identifies corollary risks with much higher potential impact than the one prompting analysis. This valuable information is lost if the circumstances cannot be recreated for analysis, such as when the user has tried to repair or hide the failure.

*In the event of any failure, the failed item will therefore be carefully maintained in its "as failed" state until root cause analysis can be completed.*

The results of the analysis will be used to determine the root cause of the out-of-specification condition, and a corrective action to eliminate the cause will be developed and implemented. Periodic checks after implementing the corrective action will be made to assess the effectiveness of the corrective action, and to further evaluate other actions that could improve the effectiveness and efficiency of the process, component, or material.

## **13.3 Parts, Materials, and Process Selection**

In accordance with the PoF methodology we are not using, parts that have a limited usable lifetime such as aluminum foil wet electrolytic capacitors, materials that are not tolerant of low temperature exposure (freezing and cracking), and assembly and manufacturing processes that adversely affect the reliability of components and materials are excluded from our critical in-ice subsystems. During IceCube Gen1 construction, our group consulted with NASA's Glenn Research Center (experts in low-temperature electronics) to provide guidance in our component and material selection.

2020001-19

### 13.3.1 Determination of Prohibited Materials

Prohibited materials include compounds, components, and materials used in assembly and processing that can outgas elements that are corrosive to metallic components, cause delamination of PWBs, cause changes in the optical and mechanical properties of the optical gel, or cause degradation of the dielectric characteristics of the electronic assemblies. Also included are materials and processes that promote the growth of electrically conductive whiskers. The system-level ERD will contain the overall list of prohibited materials, and individual subsystem ERDs are free to impose additional restrictions as dictated by the application.

### 13.3.2 Use of Commercial and Industrial Parts

The use of commercial off-the-shelf (COTS) products is becoming increasingly commonplace in high-reliability programs. Accelerating rates of COTS product enhancement is a major driver of this process. Wherever possible, we select electronic parts from “manufacturer high-reliability” parts or “industrial” parts qualified and screened in accordance with MIL-STD-883 or EIA/JEDEC approved test methods from manufacturers on the DoD Qualified Manufacturer List (QML) and NASA’s Active Parts Core Suppliers Listing (CSL). By using QML vendors we leverage the system implemented by the DoD to ensure the availability of high-quality parts in a cost-effective manner. On an electronic component-by-component basis, we require an absolute minimum for industrial or automotive ratings or that parts are explicitly denoted as high reliability.

*Collect Signatures* has completed on [IceCube Upgrade PEP 2020](#).

**Collect Signatures on IceCube Upgrade PEP 2020 has successfully completed. All participants have completed their tasks.**

**Collect Signatures started by Mike Zernick on 2/20/2020 10:05 AM**

**Signed by FARSHID FEYZI on 2/20/2020 2:06 PM**

**Signed by KAEL D HANSON on 2/26/2020 9:03 AM**

## **Appendix 1: Flow Down from Scientific Objectives to Technical Requirements**

| SCIENCE OBJECTIVES - THE ICECUBE UPGRADE            |                                                                                                                                                     |                             |                              |                              |                                                              |  |
|-----------------------------------------------------|-----------------------------------------------------------------------------------------------------------------------------------------------------|-----------------------------|------------------------------|------------------------------|--------------------------------------------------------------|--|
|                                                     | Tau Neutrino Appearance and the Unity of the PMNS Matrix (2.1)                                                                                      | Neutrino Oscillations (2.2) | Sterile Neutrinos (2.2)      | Indirect Dark Matter (2.2)   | Ice Characterization for better LE & HE flavor physics (2.3) |  |
| Event Energy Range                                  | few to 100 GeV                                                                                                                                      | few to 100 GeV              |                              |                              | TeV to >PeV                                                  |  |
| Expected Detectable Event Rate                      | Measurement in 2-3 years                                                                                                                            | 5-10% tau measurement       | Any detection/improved limit | Any detection/improved limit | 100s / year                                                  |  |
| Desired Angular Resolution                          | <5 deg at O(20 GeV)                                                                                                                                 |                             |                              |                              |                                                              |  |
| Time Resolution Within Event                        | 2-5 ns                                                                                                                                              | 2-5ns                       |                              |                              |                                                              |  |
| Absolute Time Accuracy                              |                                                                                                                                                     |                             |                              |                              | 50 ns                                                        |  |
| Instrumented Ice Volume                             | About 2 million cubic meters                                                                                                                        |                             |                              |                              |                                                              |  |
| Array Shape                                         | Compact                                                                                                                                             |                             |                              |                              |                                                              |  |
| Effective Volume                                    | Varies with energy level and event orientation (derived from other properties)                                                                      |                             |                              |                              |                                                              |  |
| Number of Strings                                   | 7                                                                                                                                                   |                             |                              |                              |                                                              |  |
| multi-PMT Digital Optical Modules (mDOM) per String | 108 (60 in the dense physics region, others above and below for primarily calibration purposes) - 46 mDOMs, 36 D-Eggs, & 6 pDOMs                    |                             |                              |                              |                                                              |  |
| Total Number of mDOM                                | ~750 (photocathode area is key parameter here)                                                                                                      |                             |                              |                              |                                                              |  |
| mDOM Spacing - Horizontal                           | 22 meters (compromise between closer and drill constraints)                                                                                         |                             |                              |                              |                                                              |  |
| mDOM Spacing - Vertical                             | 3.0 m                                                                                                                                               |                             |                              |                              |                                                              |  |
| Detector Depth                                      | Physics region: 2150-2425m Upper region: 1450-2150 Deep region: 2425-2600m                                                                          |                             |                              |                              |                                                              |  |
| Sensitivity of mDOM                                 | Single Photo Electron (SPE)                                                                                                                         |                             |                              |                              |                                                              |  |
| mDOM Photon Event Dynamic Range                     | SPE to >200 PE / 15 ns                                                                                                                              |                             |                              |                              |                                                              |  |
| mDOM Field of View                                  | Spherical with <10% variation, except for cable shadowing.                                                                                          |                             |                              |                              |                                                              |  |
| Digitization Rate                                   | 300 megasamples / second                                                                                                                            |                             |                              |                              |                                                              |  |
| Waveforms < 400 ns                                  |                                                                                                                                                     |                             |                              |                              |                                                              |  |
| Digitization Rate                                   | 40 megasamples / second                                                                                                                             |                             |                              |                              |                                                              |  |
| Waveforms > 400 ns                                  |                                                                                                                                                     |                             |                              |                              |                                                              |  |
| Absolute Amplitude Calibration Accuracy             | < 5 %                                                                                                                                               |                             |                              |                              |                                                              |  |
| Timing Accuracy                                     | < 5 ns                                                                                                                                              |                             |                              |                              |                                                              |  |
| mDOM Noise Rate                                     | O(10kHz) total noise rate, ~850 Hz per PMT                                                                                                          |                             |                              |                              |                                                              |  |
| mDOM Data Processing                                | Initial waveform capture and digitization in DOM, context sensitive compression of data prior to transfer                                           |                             |                              |                              |                                                              |  |
| Local Coincidence Function                          | In mDOMs, might require N of 24 PMTs hit within time window to suppress noise.                                                                      |                             |                              |                              |                                                              |  |
| Event Trigger Function                              | Global (surface) trigger logic to package event data and discriminate noise                                                                         |                             |                              |                              |                                                              |  |
| Veto Function                                       | Surface Array (IceTop) allows identification and discrimination of downgoing background                                                             |                             |                              |                              |                                                              |  |
| Incoming Data Stream from Sensor Array              | 150 Gg / day                                                                                                                                        |                             |                              |                              |                                                              |  |
| Non-Volatile Storage at South Pole                  | 1-2 Day Buffer / Archive Capacity & Full Redundancy Requirements                                                                                    |                             |                              |                              |                                                              |  |
| South Pole High Priority Communications             | At all times, it must be possible to complete a minimum 10KB transfer to the Northern Hemisphere within 10 minute period. (SNEWS and GRB Reporting) |                             |                              |                              |                                                              |  |
| South Pole Medium Priority Communications           | 500 MB / day                                                                                                                                        |                             |                              |                              |                                                              |  |
| South Pole High Volume Data Transfer                | >30 GB / day                                                                                                                                        |                             |                              |                              |                                                              |  |
| Northern Hemisphere Data Warehouse                  | Fully Buffered / Archive Capacity & Redundancy Requirements                                                                                         |                             |                              |                              |                                                              |  |

PRIMARY SCIENCE REQUIREMENTS

Ice Sensor Array Geometry

Individual mDOM Performance

Event / Background Discrimination (Noise Reduction)

Data Transport and Storage



2020001-19

### Appendix 3: List of Referenced Documents

The following documents are referenced in and form parts of the Project Execution Plan. The listed documents are managed separately as standalone documents.

|    |                                                                                                                                                                                                                                                            |
|----|------------------------------------------------------------------------------------------------------------------------------------------------------------------------------------------------------------------------------------------------------------|
| 1  | NSF Cooperative Agreement PLR-1600823, Management and Operations of the IceCube Neutrino Observatory 2016-2021                                                                                                                                             |
| 2  | NSF Cooperative Agreement: PHY-1719277                                                                                                                                                                                                                     |
| 3  | Memorandum of Understanding (p.18)                                                                                                                                                                                                                         |
| 4  | Project Schedule (p.18)                                                                                                                                                                                                                                    |
| 5  | In-kind Contributions (p.19)                                                                                                                                                                                                                               |
| 6  | NSF Major Facilities Guide (p.22)                                                                                                                                                                                                                          |
| 7  | WBS Dictionary (p.26)                                                                                                                                                                                                                                      |
| 8  | Cost Model Workbooks (p. 28)                                                                                                                                                                                                                               |
| 9  | IceCube Upgrade Cost Uncertainty Workbook (p. 28, 29)                                                                                                                                                                                                      |
| 10 | IceCube Upgrade Risk Register (p. 28)                                                                                                                                                                                                                      |
| 11 | IceCube Upgrade Risk Management & Mitigation Plan (p. 34)                                                                                                                                                                                                  |
| 12 | Configuration Management Plan (CMP, p. 34)                                                                                                                                                                                                                 |
| 13 | IceCube Upgrade Quality Plan (p. 35)                                                                                                                                                                                                                       |
| 14 | IceCube Upgrade Safety Manual (p.35)                                                                                                                                                                                                                       |
| 15 | Support Information Package (SIP, p. 39, accrued each March)                                                                                                                                                                                               |
| 16 | Design Documentation (p. 16) <ul style="list-style-type: none"> <li>• Engineering requirements documents (ERD)</li> <li>• Interface control documents (ICD)</li> <li>• Verification and testing documents</li> <li>• Procurement specifications</li> </ul> |

2020001-19

## Appendix 4: Contributions in Kind

Following table lists the non-NSF contributions by other agencies, also separated by project year and by WBS.

| WBS                                                | YEAR1              | YEAR2              | YEAR3              | YEAR4              | YEAR5            | TOTAL               |
|----------------------------------------------------|--------------------|--------------------|--------------------|--------------------|------------------|---------------------|
|                                                    | Total (\$)         | Total (\$)         | Total (\$)         | Total (\$)         | Total (\$)       | GRAND TOTAL         |
| <b>1.1 PROJECT MANAGEMENT</b>                      | 0                  | 0                  | 0                  | 0                  | 0                | 0                   |
| <b>1.2. The ICECUBE UPGRADE DRILL</b>              | 0                  | 0                  | 0                  | 0                  | 0                | 0                   |
| <b>1.3 DEEP ICE SENSOR MODULES</b>                 | \$2,990,308        | \$2,942,536        | \$3,478,825        | \$713,016          | \$690,038        | \$10,814,723        |
| <b>1.4 CPT DISTRIBUTION SYSTEM</b>                 | \$621,185          | \$679,573          | \$605,485          | \$97,394           | \$66,229         | \$2,069,866         |
| <b>1.5 CHARACTERIZATION AND CALIBRATION SYSTEM</b> | \$187,130          | \$340,870          | \$344,690          | \$198,584          | \$202,557        | \$1,273,831         |
| <b>1.6 M&amp;O DATA SYSTEMS INTEGRATION</b>        | 0                  | 0                  | 0                  | 0                  | 0                | 0                   |
| <b>Total Non-NSF</b>                               | <b>\$3,798,623</b> | <b>\$3,962,979</b> | <b>\$4,429,000</b> | <b>\$1,008,994</b> | <b>\$958,824</b> | <b>\$14,158,420</b> |